

mc² Manual

Digital Control Unit for EasyControl Digital System

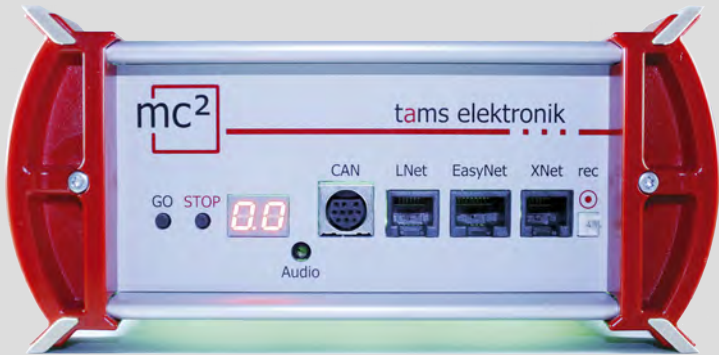

Silver Edition | Item no. 40-03007 | 40-03027 | 40-03067



Black Edition | Item no. 40-03017 | 40-03037 | 40-03077



Notes on this download version of the manual

This manual provides you with an overview of the features and functions of the digital central unit mc². However, the manual is only one part of the instructions. Another essential part is the direct help in the web interface of the central unit, the so-called mc²-Toolbox. You can connect to a real mc² digital central unit via the Internet and test the web interface.

[Link to the mc²-Toolbox](#)

Notes for users of the digital central unit mc²

This download version of the manual may not correspond to the software and/or hardware version of your mc². Please only use the version of the manual that is available for download in the mc²-Toolbox.

Manual version 1.10 03/2024

This manual is part of the user software "mc²-Toolbox" and applies to:

- Hardware of the mc²: from Version 1.4
- Hardware of the mc² V2: from Version 1.6
- Firmware of the mc²: Version 1.7.4
- Software for web interface mc²-Toolbox: Version 1.9.0

© Tams Elektronik GmbH

All rights reserved, in particular the right of reproduction, distribution and translation. Copies, reproductions and alterations in any form require the written permission of Tams Elektronik GmbH. We reserve the right to make technical changes.

Updates

Download the latest version of the manual after you have performed an update of the mc²-Toolbox (the software for the web interface of the mc²). Appendix B contains an overview of the changes and additions to the manual.

Printing the manual

The formatting is optimised for double-sided printing. The standard page size is DIN A5. If you prefer a larger display, printing on DIN A4 is recommended.

Info: Versions of the mc²

Item no.	Model	Version no.	Output current of the internal booster	Delivery
40-03007-01 40-03017-01	mc ² Silver Edition mc ² Black Edition	(V1)	maximum 6,5 A	until 02/2024
40-03027-01 40-03037-01	mc ² Silver Edition mc ² Black Edition	V2-6	maximum 6,5 A	from 03/2024
40-03067-01 40-03077-01	mc ² Silver Edition mc ² Black Edition	V2-9	maximum 9,0 A	from 04/2024

Contents

1. Getting started.....	1.1
2. Commissioning.....	2.1
3. Your mc ²	3.1
3.1. Display and operating elements.....	3.3
3.2. Protocols.....	3.4
3.3. Virtual control devices.....	3.5
3.4. External digital input devices.....	3.7
3.5. Boosters.....	3.8
3.6. PC control.....	3.10
4. Connections.....	4.1
4.1. Main and programming track.....	4.3
4.2. Connection of external digital devices.....	4.4
4.2.1. Devices for the CAN bus.....	4.4
4.2.2. Devices for the LocoNet.....	4.5
4.2.3. Devices for the EasyNet.....	4.7
4.2.4. Devices for the XpressNet.....	4.8
4.2.5. Digital central units for DCC and Motorola.....	4.9
4.2.6. Wireless control units for the Z21 protocol.....	4.10
4.3. Connecting BiDiB devices.....	4.11
4.4. Connection of s88 feedback modules.....	4.12
4.4.1. Power supply of the devices on the s88 bus.....	4.13
4.5. Connection of external boosters.....	4.14
4.5.1. Booster interfaces.....	4.14
4.5.2. Recommendations for the use of external boosters.....	4.15
4.5.3. Example: Use of a Power-Splitter.....	4.17
4.5.4. Examples: Separate "Driving" and "Switching".....	4.17
4.5.5. Examples: Additional boosters for driving operation.....	4.19
4.5.6. Assignment of the track connection to the rails.....	4.20
4.5.7. Configuration.....	4.20
4.6. Connection to the audio output.....	4.21
5. Configuring the system (Submenu "System").....	5.1
5.1. System Info.....	5.1
5.2. Vehicles.....	5.3

5.3. Accessories.....	5.5
5.4. Protocol.....	5.6
5.5. Boosters.....	5.7
6. Operation with the mc ²	6.1
6.1. Operating and display elements.....	6.1
6.1.1. STOP and GO buttons.....	6.1
6.1.2. Display and RGB-LEDs.....	6.2
6.2. Submenu "Operation".....	6.4
6.2.1. Feedback.....	6.4
6.2.2. Programming.....	6.5
6.2.3. Messages.....	6.7
6.2.4. BiDiB.....	6.7
6.2.5. Control.....	6.8
6.2.6. Model time.....	6.8
6.2.7. Signal box.....	6.8
6.3. Virtual control devices.....	6.9
6.3.1. HandControl.vi.....	6.9
6.3.2. FunctionControl.vi.....	6.11
6.3.3. DriveControl.vi.....	6.12
6.3.4. SwitchControl.vi.....	6.13
6.3.5. LocoControl.....	6.14
6.4. Signal box.....	6.15
6.4.1. Track diagram.....	6.15
6.4.2. Automatic train control.....	6.17
7. Updates.....	7.1
8. Checklist for troubleshooting.....	8.1
8.1. Heat generation.....	8.1
8.2. Automatic safety shutdown.....	8.1
8.3. Problems with the power supply.....	8.2
8.4. Problems with external input devices.....	8.2
8.5. Problems when programming and controlling vehicles.....	8.3
8.6. Problems when switching points and other accessories.....	8.4
8.7. Problems with s88 modules.....	8.4
8.8. Problems with the software update.....	8.5
8.9. Technical hotline.....	8.6
8.10. Repairs.....	8.6

9. Technical data.....	9.1
9.1. Digital control unit mc ²	9.1
9.2. Power supply unit for versions V1 and V2-6 of the mc ²	9.4
9.3. Power supply unit for version V2-9 of the mc ²	9.6
10. Warranty, EC Conformity & WEEE.....	10.1
10.1. Warranty Statement.....	10.1
10.2. EC Declaration of Conformity.....	10.2
10.3. Declarations on the WEEE Directive.....	10.2
Appendix A: Organisations, Manufacturers, Products.....	
Appendix B: Changes and additions.....	

tams elektronik

tams elektronik

1. Getting started

The instructions for the digital central unit mc² consist of the following parts:

- the guide, which is enclosed with the delivery in printed form and which contains all the information you need for safe and proper commissioning of the mc². The contents of the guide are also included in this manual. Nevertheless, keep the guide carefully in case you want to commission the mc² again and do not have access to the manual. If you pass the digital central unit on to another person, also give the guide with it.
- this manual, which is available for download in the mc²-Toolbox (the web interface of the central unit). In the manual you will find all the information you need for safe and proper connection to your system and external devices, as well as an overview of the configuration of your mc² and instructions for operation. Note: The manual applies to the software version(s) of the mc² indicated on page 0.2 of this manual.
- the direct help in the mc²-Toolbox

Contents of the package

After unpacking, check the delivery for completeness:

- mc² digital control unit
- power supply unit
- mains cable (black) with Euro plug (CEE 7/16) and plug for mains cable socket (European version / C7)
- connection cable (grey) with RJ-45 connectors (at least Cat. 5e)
- one 4-pole plug for connection to main and programming track and one 3-pole plug for connection to external boosters
- one RJ 45 blind connector (plugged into BiDiB connector)
- 4 plastic brackets for mounting the mc²
- guide, "Important notes" sheet and sticker sheet for labelling the connection cables

Required additional equipment

It is not possible to use the mc² digital control unit without additional devices. You can use the following devices for commissioning, configuration and operation of the model railway layout:

	Commissioning	Configuration	Operation
PC	X	X	X
Tablet and WLAN router)	X	X	X
Smartphone (and WLAN router)	X	X (not recommended)	X
HandControl 2	---	X (restricted)	X
Other digital control devices	---	---	X

Intended use

The digital control unit mc² is intended for controlling digital model railway layouts according to the information in the instructions (consisting of guide, manual and direct aids). Only the power supply unit included in the scope of delivery is permitted for the power supply. Any other use is not in accordance with the intended use and will result in the loss of the warranty claim. Intended use also includes reading, understanding and following all parts of the instructions. The mc² is not intended to be used by children under the age of 14.

Safety instructions

Improper use and non-observance of the instructions can lead to incalculable hazards. Prevent these dangers by carrying out the following measures:

- Use the digital control unit and the power supply unit only in closed, clean and dry rooms. Avoid humidity and splash water in the environment. After condensation has formed, wait two hours for acclimatisation before use.
- Disconnect the control unit from the power supply before carrying out wiring work.
- Only plug the mains plug of the power supply unit into properly installed and fused earthed sockets.
- Heating of the control unit and the power supply unit during operation is normal and harmless. Keep a distance of at least 20 cm between the sides, the top and the back to surrounding surfaces to allow unhindered air exchange and to prevent the units from overheating.
- Do not expose the units to high ambient temperatures or direct sunlight. Observe the information on the maximum operating temperature in the technical data.
- Regularly check the operational safety of the units, e.g. for damage to the connection cables or damage to the housing.
- If you notice damage or if malfunctions occur, switch off the supply voltage immediately. Send in the control panel and/or the power supply unit for inspection.
- Dangerous voltages occur inside the power supply unit. Therefore, never open the housing of the power supply unit.

Care

Do not use any cleaning agents to clean the mc² and the power supply unit. Only wipe the units dry. Disconnect the units from the power supply before cleaning.

2. Commissioning

After commissioning, you must first configure your mc², i.e. adapt it to your ideas and adjust it to the conditions of your model railway layout. It is therefore not recommended to start up the mc² with a smartphone, as the display of the mc²-Toolbox (the web interface of your control unit) is unclear due to the small screen size.

Direct connection to the PC

You can connect your mc² directly to your PC.



Plug the (grey) patch cable on one side into the LAN interface of the mc² and on the other side into the RJ45 socket of the network interface of your computer.

Connecting to the Intranet / Internet

By connecting your mc² to your router, you can use devices such as a PC, tablet or smartphone that also have a connection to the router to configure your mc² and control your system. You can also use the router to connect to the Internet, which you need to check for updates.



Plug the (grey) patch cable into the LAN interface of the mc² on one side and into a free RJ45 socket of the router on the other side.

Never pull out the patch cable by force!



Patch cables with RJ45 connections have a small locking tab. This must be pressed completely against the plug to release the lock.

Never pull the patch cable out of the socket by force if you feel any resistance! Doing so will damage the interface of your m.

If you cannot reach the tab with your finger, you can use a screwdriver, for example, to press the tab (see illustration).

Connection to the power supply

! Note:

Only use the power supply unit supplied as a power supply for your mc² and the components of your system that are supplied by the integrated booster.



First, plug the 4-pin connector of the power supply connection cable into the "Power" socket on the back of the mc² so that the flat part of the plug points upwards.

! Note:

The device plug of the MEAN WELL GSM160B24-R7B and GSM220B24-R7B power supply units has a locking mechanism that prevents the power supply connection cable from being accidentally pulled out. To be able to pull out the cable, you must pull the catch in the direction of the cable. Never pull the cable out of the socket by force! Doing so may damage connections in your mc².

Then plug the supplied (black) mains cable into the connection socket of the power supply unit and into the socket.

Reading out the IP address of the mc²

Press the "STOP" button and switch off the track voltage.

Then press and hold the "GO" button on the mc² until "IP" appears on the display. Press the "GO" button again and the digits of the IP address will gradually appear. Tip: Make a note of the digits including the dots.

Example of an IP address:	192.178.001.010	
Shown on the display:	19 2.1 78. 00 1.0 10	Two digits and the dots are shown in the display.
Input in the browser:	192.178.1.10	Leading zeros (after a dot) should not be entered.

Calling up the IP address in the browser

The mc²-Toolbox (i.e. the web interface of the mc²) has been tested with the browsers Chrome, Firefox, Opera and Edge. The use of the browsers Internet Explorer and Safari is not recommended, as they do not support all the required functions.

Enter the read IP address in the browser of the PC, tablet or smartphone. The start page ("Home") of the mc²-Toolbox will then open.

User settings in the mc²-Toolbox

Set the following on the start page of the web interface of your mc²:

- language
- Display of the submenu items: Change the display by clicking on the symbols.



Submenu items are always displayed



Submenu items are only displayed after clicking on the higher-level main menu item.

Downloading the manual

Before connecting the mc² to your model railway layout, download the manual from the start page of the mc²-Toolbox ("Home") and read it carefully. In the manual you will find all the information you need to connect to your layout and external devices, as well as an overview of the configuration of your mc² and notes on its operation.

In the manual you will also find the troubleshooting checklist, the technical data of the control unit and the power supply unit and the warranty declaration.

Before the first test drive

For a first test run you can connect your mc² e.g. to a separate track oval, for which the integrated booster is sufficient as a power supply, and familiarise yourself with the functions of the control unit.

You have to do the following things before you can do a first round with a locomotive:

- Connect the track output of the mc² to the rails (→ section 4.1 in the manual).
- Configure the integrated booster, i.e. set the track voltage and the maximum current for the nominal width of your layout (→ menu item "System / Boosters").

To control a locomotive, proceed as follows:

- DCC decoder: Open the virtual HandControl on the start page ("Home") of the mc²-Toolbox. Enter the DCC address and control the locomotive. For the functionality of the HandControl.vi → section 6.3.1 in the manual.
- MM decoder: Before you can control a locomotive with the HandControl.vi, you must create the MM address in the locomotive list and assign an MM format to the locomotive (→ menu item "System / Vehicles").
- mfx decoder: First read out the UID and assign an address to the decoder (→ menu item "Operation / Programming / m3"). You can then control the locomotive in m3 format with HandControl.vi.

Setting the display of the submenu

Selecting the language

- mc² Toolbox
© Tams Elektronik GmbH
- Home
- System
- Operation
- Update
- Experts

E = mc²
Easy = MasterControl.2

Language: English



Virtual control units



Central unit is not locked. Password: Lock



New: New: Old: Set

User information

The mc² web interface (mc²-Toolbox) has been tested with the browsers Chrome, Firefox, Opera and Edge. The use of the browsers Internet Explorer and Safari is not recommended, as they do not support all required functions. A prerequisite for the safe and proper use of the digital central unit mc² is the observance of all parts of the instructions. The instructions for the mc² consist of the following parts:

- the printed guide, which is included with the mc²
- the manual, which is available for download in the footer of the mc²-Toolbox
- the direct helps next to the input fields of the mc²-Toolbox, marked by ?

(De)activating "Boredom Mode"

Dimming RGB LEDs (red and green only)

(De)activating Tip of the Day

- Light Effects
- Dim light
- Tip of the Day

3. Your mc²

The main tasks of your mc² include,

- to send the digital driving and switching commands to the vehicle and accessory decoders
- to receive and forward the feedback signals from decoders and feedback units
- to serve as a "medium" for programming the decoders.

Furthermore

- a booster is integrated in your mc², which brings the digital signals to the track and supplies the vehicles with power.
- your mc² acts as an interface to various additional devices such as external input devices, feedback devices, PC and mobile devices.

Browser-based

Your mc² uses the possibilities offered by PCs, mobile devices such as smartphones or tablets and fast Internet in private households.

The web interface "mc²-Toolbox", i.e. the software with which you configure your digital control and control your system, is called up via the browser of a PC, tablet or smartphone. You then have access to all functions of the mc². The mc²-Toolbox is installed on your mc² and you can perform updates for it in the same way as for the firmware of the central unit. You do not need to install any software or app on your PC or mobile devices. The question of whether the operating systems of the various devices are compatible with each other is therefore irrelevant.

You can connect the mc² to your home network and the Internet via a router. Connection to a Wlan router is a prerequisite for the use of mobile end devices. Alternatively, you can connect a PC directly to your mc² (without a diversion via a router). An Internet connection is only absolutely necessary if updates are to be requested.

The mc² Toolbox

With the Toolbox (the web interface of the mc²) you manage your digital control including all connected input devices, feedback devices and boosters. You can

- configure your mc², i.e. adapt it to your ideas and the conditions of your layout
- manage and programme your vehicle and accessory decoders in an integrated database
- manage your feedback devices and query messages from the various data buses (BiDiB, s88, Märklin-CAN, LocoNet)
- store the track diagram of your layout in the "signal box" and set up and retrieve automated sequences for trains
- display RailCom and BiDiB messages
- carry out updates

Input and control devices

For the control of your layout you have various possibilities open to you, which you can also combine with each other as you wish:

- virtual control devices that you open on your smartphone, tablet or PC (→ section 3.3)
- digital input devices from various manufacturers (→ section 3.4)
- special PC control software (→ section 3.6)

tams elektronik

3.1. Display and operating elements

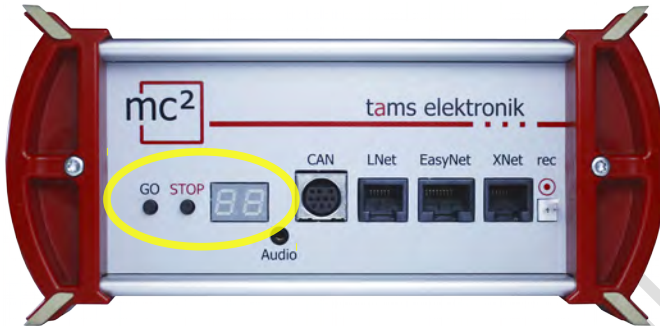

STOP & GO

These two buttons of the mc² are used

- to switch the track voltage on and off
- to trigger a reset
- as a trigger for displaying the IP address
- to delete the internal configuration

Display

The 2-digit 7-segment display shows you essential information, e.g.

- the current consumption in the booster circuit of the internal booster
- the operating status (short circuit, stop, normal operation)
- the IP address (due to the limitation to 2 display fields in several "sequences")
- the progress of an update

RGB LEDs in the housing

The top and bottom of the mc² are made of translucent plastic. During operation, RGB LEDs built into the housing visibly indicate the operating status of the mc² from a distance, e.g. green for "normal operation" or red for "stop, track voltage is switched off".



Track voltage = off



Track voltage = on

3.2. Protocols

Digital formats

The mc² sends digital driving and switching commands to the vehicle and accessory decoders in the following formats:

- **DCC:** 14, 28 or 128 speed steps
- **Motorola:** I and II (14 or 28 speed steps)
- **m3:** This format enables the control of vehicle decoders for the mfx protocol. Note: Automatic registration of mfx decoders with the command station is not possible.

BiDiB

The mc² is simultaneously a BiDiB interface and BiDiB track output device in the sense of the BiDiB specification.

Up to 31 nodes of one level can be connected to the BiDiB interface of the mc². With appropriate PC control software, digital commands can be sent and messages received and evaluated via the BiDi bus.

CAN, EasyNet and XpressNet

These protocols exclusively define the communication between input devices (e.g. hand controllers) and the mc², but not the transmission of digital commands or feedback signals.

DCC-A

The RailCom-based extension of the DCC format in accordance with RailCommunity standard RCN-218 enables automatic registration of vehicle decoders with the control unit. The decoder properties are read out by the control unit immediately after rerailing and stored in the internal database, where they can be further processed.

LocoNet

LocoNet manual controllers and stationary LocoNet devices can be connected to the LocoNet interface (accessory decoders, feedback devices and, from version 2 of the mc², also boosters). Switching commands are sent to LocoNet devices via LocoNet and feedback from LocoNet devices is analysed.

RailCom

A global RailCom detector is integrated in the mc², which receives the messages from the RailCom decoders and forwards them to the PC. For forwarding the RailCom messages to the PC control software, the mc² uses the BiDiB protocol.

s88

Up to 52 s88 or s88-compatible modules (= 832 contacts) can be connected to the s88 interface. Note: The s88-compatible modules also include, for example, feedback devices that are connected via the CAN bus interface.

Data transmission to the PC

For information on the protocols used for data transmission between the mc² and the PC, see section 3.6.

3.3. Virtual control devices

From the Toolbox, you have access to various virtual control devices to control your layout. The virtual control devices are optimised for use with smartphones or tablets, but can just as easily be used from the PC screen.



The HandControl.vi is similar to the real HandControl.2 and can be used to call up vehicles and switch functions up to F9.

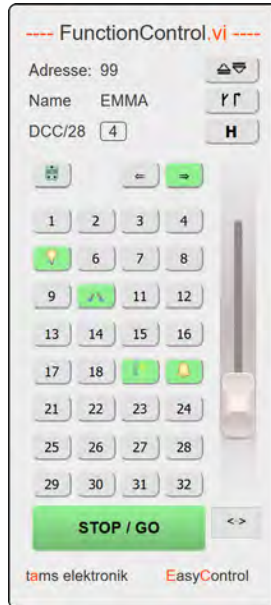

With the FunctionControl.vi locomotives can be controlled sensitively and functions up to F32 can be switched.



The SwitchControl.vi is intended for switching turnouts (or other stationary components). The last locomotive called up remains under control.

With DriveControl.vi, 4 locomotives can be accessed simultaneously. The speed level can be set, the direction of travel can be changed and the F0 function can be switched on and off.



LocoControl.vi enables quick access to up to 9 vehicles. The speed level can be set for the active vehicle, the direction of travel can be changed and the functions F0 to F31 can be switched on and off.



3.4. External digital input devices

The mc² has interfaces for various wired digital input devices from different manufacturers. You can integrate manual control units and/or digital control centres for the following bus systems into your digital control system via the interfaces:

- Märklin CAN-Bus
- LocoNet
- XpressNet
- EasyNet

Via the universal interface "rec" you can also integrate all digital control units for the DCC or Motorola format that have a track output into the EasyControl system and use them as external control and switching devices.

It is also possible to integrate wireless digital devices that support the Z21 protocol into the EasyControl system.

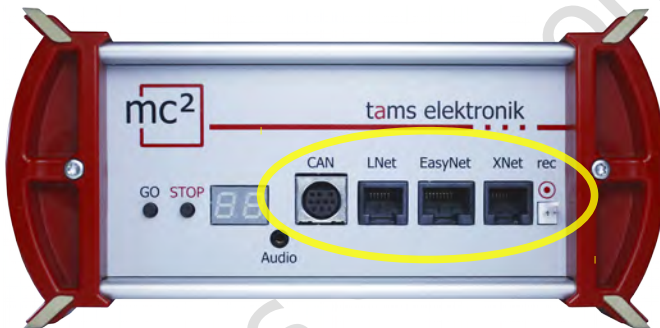

Possible applications for external digital input devices

	Driving (controlling vehicle decoders)	Switching (controlling accessory decoders)	Programming (programming decoders)	Configuring (setting up the digital system control / mc ²)
CAN	X	X	---	---
LNet	X	X	---	---
EasyNet	X	X	X	possible (with limitations)
XNet	X	X	X (POM only)	---
rec	X	X	---	---
Z21	X	X	---	---

3.5. Boosters

Integrated booster

A booster is integrated in the mc². The maximum output current depends on the version:

mc ² Version 1	Maximum 6.5 A	
mc ² Version 2 (delivery from 03/2024)	Version 2-6: maximum 6.5 A (rated current power supply unit: 6.7 A)	Version 2-9: maximum 9 A (rated current power supply unit: 6.7 A)

Depending on the nominal size, the maximum output current must be limited in a booster section. In order to utilise the current of 6.5 or 9 A that the integrated booster of the mc² can provide, even with smaller nominal sizes, a Power-Splitter (item no. 40-20107) can be used. The Power-Splitter distributes the current to 2 to 3 booster sections with 2 to 3 A each.

- Short-circuit sensitivity: 1 - 6.5 A or 1 - 9 A. It can be adapted to the nominal size of the installation in steps of 0.5 A.
- Track voltage: 8 - 22 V. It can be adjusted in steps of 1 V.
- Track signal: symmetrical
- RailCom cutout: can be switched off.

The status messages of the integrated booster are reported to the control software via BiDiB. They are then available as a basis for booster management.

External boosters

If the integrated booster is not sufficient for operating the layout, or if the signals for vehicle and accessory decoders are to be output separately, additional external boosters can be connected. Märklin-compatible (ground-related) boosters or DCC-compliant (galvanically isolated) boosters can be connected to the booster interface.



Note:
All information in this section applies to both version 1 and version 2 (V2) of the mc².

⚠ Attention!

Before connecting external boosters, be sure to read section 4.5! If you do not observe the information in section 4.5, your mc² and external boosters may be damaged (possibly irreparably)!

BiDiB boosters

Boosters according to the BiDiB specification can be connected directly to the BiDiB interface.

LocoNet boosters

Version 1 of the mc²: Boosters for use in LocoNet cannot be connected to the LocoNet interface of the mc², as this is designed as a LocoNet T(ool) interface - and not as a LocoNet B(ooster) interface. No booster signals are transmitted on the LocoNet interface of version 1 of the mc². LocoNet boosters must therefore be connected to one of the two interfaces for external boosters.

Version 2 of the mc²: Version 2 of the mc² has a combined T(ool) and B(ooster) LocoNet interface to which all types of LocoNet devices, including boosters, can be connected. Note: Commands for switching LocoNet boosters on and off and the transmission of feedback from LocoNet boosters to the control unit are not yet supported (as of 03/2024).

Output of the driving and switching commands

For the track output of the integrated booster and the interfaces for Märklin-compatible and DCC-compliant boosters it is set separately whether

- driving and switching commands or
- only driving commands

are to be output. The setting for the integrated booster also applies to boosters on the BiDiB interface.

3.6. PC control

Protocols: BiDiB, p50x and Z21

For the encryption of the data exchanged between the central unit and the PC control software, the mc² uses the BiDiB protocol or the p50x or Z21 protocol.

With software that supports BiDiB, all the possibilities offered by bidirectional communication via the BiDiBus can be used. These include e.g.:

- the direct sending of digital commands to the stationary BiDiB nodes via the BiDiBus cables (e.g. to the accessory decoders)
- receiving feedback from the stationary BiDiB nodes (e.g. from boosters and accessory decoders).
- the reception of messages from the global RailCom detector integrated in the mc².

If these possibilities are utilised, the safety and the transmission speed in PC-controlled systems are significantly increased.

If the BiDiB protocol is not supported by the PC control software, data can be transferred between the mc² and the PC via the p50x or Z21 protocol. BiDiB nodes can then not be used or only to a limited extent. BiDiB feedback modules are treated like s88 feedbacks, for example. The transmission of RailCom messages of the integrated global RailCom detector to the PC control software is then not possible.

TCP to TCP

By default, the data is transmitted from the mc² to the PC or router via the LAN interface using the network protocol TCP ("Transmission Control Protocol"). Whether the data is encrypted in the BiDiB or p50x or Z21 protocol is irrelevant. Many newer versions of model railway control programs support TCP.



TCP to COM: Setting up a virtual COM port

With older model railway control programmes or older versions of the control programmes, the data transfer between PC and digital control unit is usually based on the RS-232 standard for serial interfaces. In most cases, these programmes use only the p50x protocol for encoding the data.

The prerequisite for using these programmes is the setting up of a virtual serial interface (or in other words: a virtual COM port). Various programmes are available on the internet for this purpose, with the help of which a driver for a virtual COM port can be set up on the PC.

4. Connections

The mc² has various interfaces for different bus systems, which you can use to connect to external control devices, stationary components in your layout and to the router or computer.

Interface	Version	for:
CAN	10-pole	Devices for the Märklin CAN bus (e.g. Mobile Station 2 and 3 and Märklin)
LNet	RJ 12	LocoNet devices (e.g. FRED and DAISY 2 handheld controllers from Uhlenbrock, SmartControl Light from Piko, stationary LocoNet devices)
XNet	RJ 12	XpressNet input devices (e.g. Lenz handheld controllers, Lokmaus and Multimaus from Roco)
EasyNet	RJ 45	EasyNet devices (e.g. HandControl, LokControl, mControl)
	RJ 45	Stationary BiDiB devices
	RJ 45	s88 feedback modules
	RJ 45	LAN network interface of the router or computer

Plug & Play

You can establish or interrupt connections to and from external devices to your mc² at any time - even during operation (plug and play).

Please note that the mc² has identical plug connections (RJ 12 and RJ 45) for different bus systems. Therefore, be very careful when plugging in the connection cables! Make sure that you do not accidentally plug the cables into the wrong sockets!

Danger of confusion!

If you plug a bus cable into the wrong socket, **irreparable damage** to your mc² and/or the connected devices can occur in the worst case.

If you plug connection cables with RJ12 plugs into RJ45 sockets, the connection pins in the socket will be bent. In this case, we recommend sending the control unit in for repair.

Avoid risks due to incorrect assignment of bus cables by labelling the connection cables (e.g. with the labels included in the delivery) and/or using different coloured cables for the different bus systems (see examples on the right).

EasyNet	
s88-Bus	
BiDi-Bus	
Ethernet (LAN)	

⚠ Never pull out the cables by force!



Cables with RJ12 and RJ45 connections have a small locking tab. This must be pressed completely against the plug to release the lock.

Never pull the cable out of the socket by force if you feel any resistance! Doing so will damage the interface of your mc².

If you cannot reach the tab with your finger, you can use a screwdriver, for example, to press the tab (see illustration).

Info: Bus cables

Various cable types are available for connections to RJ 12 and RJ 45 sockets:





- so-called standard 1:1 cables, where the wires are connected 1:1 through and
- so-called crossover cables, where the wires are connected crosswise.

⚠ Only use 1:1 cables!

Never use crossover cables for connections to interfaces with RJ-12 or RJ45 sockets of the mc². **This can cause irreparable damage to the control unit!**

Info: Distributors

To enable the use of several digital control units on one interface, you can use terminal blocks or Y-distributors:

LocoNet and XpressNet RJ12	EasyNet RJ45
 <p>Y-distributor RJ12 (item no. 73-80493-01) Input: 1 x RJ12 Output: 2 x RJ12</p>	 <p>Y-distributor RJ45 (item no. 73-80190-01) Input: 1 x RJ45 Output: 2 x RJ45</p>
<p>XL-Terminal block (item no. 73-80496-01)</p>  <p>Input: 1 x RJ12 Output: 5 x RJ12</p>	<p>EasyNet-Terminal block (item no. 73-80195-01)</p>  <p>Input: 1 x RJ45 Output: 4 x RJ45</p>

4.1. Main and programming track

Connect the two track connections of the integrated booster

- with the two rails (for 2-conductor systems) or
- with one rail and the centre conductor (with 3-conductor systems).

The feeding of the booster current into the track should be done at a distance of approx. 2 to 3 m from a ring line, because the resistances at the transitions of the track sections are quite high. If the distances are chosen too large, there may be problems with the short-circuit feedback or with the power supply to the vehicles.



Version 1 of the mc²



Version 2 of the mc²

Use the 4-pin connector supplied to connect the cables leading to the main track ("Main") or to the programming track ("Prog").

Insert the connecting cables into the plug part, screw them tight and then plug the plug part onto the socket on the back of the mc² in such a way that the screws point upwards.

Recommended cable cross-sections

- Programming track: 0.75 mm²
- Main track: 0.75 to 2.5 mm² (depending on the current)

Booster configuration

Hint:

Before you start operation on your layout, you must configure the booster (→ section 5.5). If the track voltage and/or the max. current are set too high, damage to the tracks and/or vehicles can occur during operation.

Programming track

You can use a separate piece of track as a programming track or a section of track on your layout (e.g. a siding) that you can electrically separate from the rest of the layout during programming.

Hint:

If you integrate the programming track into your model railway layout, you must ensure that both tracks are electrically separated from the rest of the layout during programming. **Otherwise the programming track connection of the mc² can be damaged!** In addition, you will otherwise program all decoders on the layout that react to the set data format.

4.2. Connection of external digital devices

4.2.1. Devices for the CAN bus

Info

The CAN bus is actually a data bus developed for the (car) industry and is used by various model railway manufacturers for communication between digital devices. Note: The manufacturers use different data protocols, therefore the devices of different manufacturers cannot communicate with each other. The protocol of the CAN interface of the mc² is that of the Märklin CAN bus.

Connection: 10-pole



For the connection of

- Mobile Station 2 and 3 (not MS 1)
- Central Station 2 and 3 (configured as "Slave")
- Feedback units for the Märklin CAN bus

Note: The feedback units send their data via the CAN bus, the data protocol corresponds to the s88 bus.

Possible applications of the CAN input devices

You can use the input devices that you integrate into the digital control system via the interface for the CAN bus for

- to control vehicle decoders for Motorola, DCC and mfx (the latter in m3 format) or
- to switch accessory decoders for Motorola and DCC

However, it is not possible to program decoders or configure the digital system using CAN input devices.

Power supply of the devices at the CAN interface

Devices such as the hand control units Mobile Station 2 and 3 are supplied with power via the bus line. The Central Station 2 and 3 control units and feedback devices for the CAN bus have their own power supplies.

! Notice:

The total current of all external digital devices that are connected to the various interfaces of the mc² and do not have their own power supply must not exceed 1.2 A. Otherwise, the mc² automatically switches off the power supply for the external devices.

4.2.2. Devices for the LocoNet

Info

The mc² has a LocoNet interface to which digital devices can be connected whose data transmission takes place via the LocoNet developed by Digitrax. Connection: RJ12

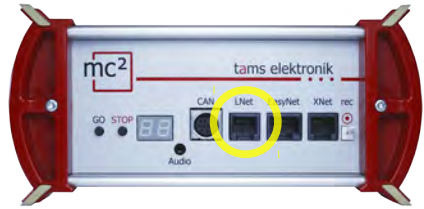

Please note:

The LNet interfaces of versions 1 and 2 of the mc² are designed differently!

	mc ² Version 1	mc ² Version 2
The version of the mc ² can be recognised by the design of the track connection and the labelling on the back.		
Version of the LocoNet interface	<input checked="" type="checkbox"/> LocoNet-T(ool) interface	<input checked="" type="checkbox"/> LocoNet-T(ool) interface <input checked="" type="checkbox"/> LocoNet-B(ooster) interface
Internal galvanic isolation	---	<input checked="" type="checkbox"/>
Connection of LocoNet control units	<input checked="" type="checkbox"/> Handheld controller FRED from Uhlenbrock <input checked="" type="checkbox"/> DAISY 2 hand controller from Uhlenbrock <input checked="" type="checkbox"/> SmartControl light from Piko	<input checked="" type="checkbox"/> Handheld controller FRED from Uhlenbrock <input checked="" type="checkbox"/> DAISY 2 hand controller from Uhlenbrock <input checked="" type="checkbox"/> SmartControl light from Piko
LocoNet accessory decoders and LocoNet feedback devices	<input checked="" type="checkbox"/> only devices with internal galvanic isolation	<input checked="" type="checkbox"/> devices with internal galvanic isolation <input checked="" type="checkbox"/> devices without internal galvanic isolation
Connection of LocoNet boosters	---	<input checked="" type="checkbox"/>

Possible applications of the LocoNet input devices

You can use the input devices that you integrate into the digital system via the LocoNet interface to

- control vehicle decoders for Motorola, DCC and mfx (the latter in m3 format)
- switch accessory decoders for Motorola and DCC

However, it is not possible to programme decoders or configure the digital system using LocoNet input devices.

Version 1 of the mc²

Connection of LocoNet feedback devices and accessory decoders

When connecting to version 1 of the mc², use LocoNet feedback devices and accessory decoders that are internally galvanically isolated between the track and Loconet connection. Alternatively, you must take other measures to ensure galvanic isolation between the layout and feedback devices or accessory decoders on the one hand and the mc² on the other.

 **Note:**

If there is no galvanic isolation between the layout and LocoNet devices on the one hand and the mc² on the other, a short circuit will occur. This can irreparably destroy one or more of the devices involved.

Connection of LocoNet boosters

Version 1 of the mc² has a pure LocoNet T(ool) interface to which no LocoNet boosters can be connected.

 **Note:**

If a LocoNet booster is connected to the LNet interface of version 1 of the mc², the control unit may be damaged during commissioning.

Version 2 of the mc²

Connection of LocoNet feedback devices and accessory decoders

Version 2 of the mc² has a LocoNet interface that is galvanically isolated internally between the track and Loconet connections. You can connect both LocoNet devices with and without internal galvanic isolation to this interface without any additional measures.

Connection of LocoNet boosters

Version 2 of the mc² has a combined T(ool) and B(ooster) LocoNet interface to which all types of LocoNet devices, including boosters, can be connected. Note: Commands for switching LocoNet boosters on and off and the transmission of feedback from LocoNet boosters to the control unit are not yet supported (as of 03/2024).

Power supply of the devices at the LocoNet interface

LocoNet manual control devices are usually supplied via the bus line. Other LocoNet digital devices such as control units, boosters, feedback units or accessory decoders have their own power supplies.

 **Note:**

The total current of all devices on the LocoNet interface must not exceed 500 mA. The total current of all external digital devices that are connected to the various interfaces of the mc² and do not have their own power supply must not exceed 1.2 A. Otherwise, the mc² will automatically switch off the power supply for the external devices.

4.2.3. Devices for the EasyNet

Info

The EasyNet is the data bus for the EasyControl digital system. Devices and adapters that have been specially developed for this system communicate via this bus.

Connection: RJ45

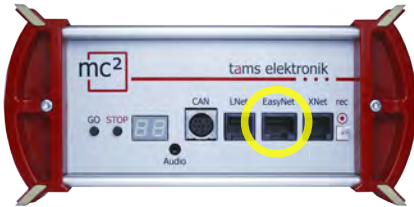

For the connection of

- HandControl and HandControl 2
- LokControl
- MasterControl (with configuration as "slave")
- mControl

Note: The connection of the adapters XNControl, SniffControl or wControl does not make sense, as corresponding interfaces are integrated in the mc².

Possible applications of the EasyNet input devices

You can use the input devices that you integrate into the digital system via the EasyNet interface

- to control vehicle decoders for Motorola, DCC and mfx (the latter in m3 format)
- to switch accessory decoders for Motorola and DCC
- to program vehicle decoders and accessory decoders
- to configure essential properties of the mc² / the digital system

Note: It is not possible to program decoders or to configure the mc² and the digital system with input devices that are integrated into the EasyNet via the mControl (Keyboard 6040, Memory 6043, driving consoles Control 80 or 80F and Infra Control 80F from Märklin).

Power supply of the units at the EasyNet interface

The EasyNet control units HandControl and HandControl.2, LokControl and MasterControl with configuration as slave are supplied via the bus line. A separate power supply is required for the mControl adapter and the connected digital devices.

Notice:

The total current of all external digital devices that are connected to the various interfaces of the mc² and do not have their own power supply must not exceed 1.2 A. Otherwise, the mc² automatically switches off the power supply for the external devices.

4.2.4. Devices for the XpressNet

Info

The Xnet interface enables the connection of input devices that establish the connection to the digital control centre via the XpressNet developed by Lenz Elektronik.

Connection: RJ12



For the connection of

- Lenz hand controllers (e.g. LH100 and LH101)*
- Locomouse from Roco (from version 2)
- Multimouse from Roco

* For the connection of Lenz hand controllers, an additional adapter may be required.

Possible applications of the XpressNet input devices

- You can use the input devices that you integrate into the digital system via the XpressNet interface
- to control vehicle decoders for Motorola, DCC and mfx (the latter in m3 format),
- to switch accessory decoders for Motorola and DCC,
- to program decoders using main track programming (POM).

However, it is not possible to use XpressNet input devices to program decoders on the programming track or to configure the digital system.

Power supply to the devices on the XpressNet interface

Input devices for the XpressNet are supplied via the bus line.

Notice:

The total current of all external digital devices that are connected to the various interfaces of the mc² and do not have their own power supply must not exceed 1.2 A. Otherwise, the mc² automatically switches off the power supply for the external devices.

4.2.5. Digital central units for DCC and Motorola

Info

The interface "rec" receives track signals in DCC and Motorola format. It is therefore the universal interface for connecting all DCC and MM digital central units with a track output (a so-called "sniffer"). It is used to integrate disused digital central units as control and switching devices into the EasyControl system.

Connection: 2-pole, grid dimension 2.54 mm. Tip: For the connection use e.g. the DCC programming cable item no. 40-01009-01. This cable has a 2-pole socket which you can plug directly onto the connection.



For the connection of e.g.

- Märklin Control Unit 6020 and 6021
- Märklin Central Station (from version 1)
- Uhlenbrock Intellibox

Possible applications of DCC and Motorola digital command stations

You can use the central units, which you integrate into the digital system via the interface "rec" (the sniffer),

- to control vehicle decoders for Motorola, DCC and mfx (the latter in m3 format),
- to switch accessory decoders for Motorola and DCC.

However, it is not possible to programme decoders or configure the digital system using the digital central units.

4.2.6. Wireless control units for the Z21 protocol

Info

As of software version V1.4.0, the mc² supports the Z21 LAN protocol developed and published by Modelleisenbahn GmbH, which regulates wireless communication between external Z21 control units and the digital control centre.

For the use of e.g.

- Roco / Fleischmann Z21 WLAN-MOUSE. Note: The wired (Z21) multi-mouse is connected to the mc² via the Xpress-Net interface.
- Lokstoredigital handheld controller LoDi-Con B
- Tablet or smartphone with Z21 app

To integrate a wireless Z21 control device into the digital system, you must first connect it to the network and then enter the IP address of your mc² on the device or in the app.

Possible uses of Z21 control devices

You can use the Z21 input devices, which you integrate into the digital system via WLAN, to

- control vehicle decoders for Motorola, DCC and mfx (the latter in m3 format)
- switch accessory decoders for Motorola and DCC

However, it is not possible to programme decoders or configure the digital system using Z21 input devices.

4.3. Connecting BiDiB devices

Info

BiDiB is a universal data bus that enables bidirectional communication between all stationary components of a digital control system.

Connection: RJ45

Notice:

On delivery, an RJ 45 blind plug is plugged into the BiDiB connection. If you are not using this interface, you should not remove the plug. This will prevent you from accidentally plugging s88 bus cables into this interface, which can cause serious damage to the mc².

Connection options

At the BiDiB interface of the mc², digital commands and track signals are output and the feedback signals from the BiDi bus are received.



For the connection of max. 31 BiDiB nodes of one level, e.g.

- BiDiB accessory decoders
- BiDiB feedback modules
- BiDiB boosters

A supply voltage of 12 V is applied to the BiDiB interface. BiDiB nodes can be supplied with a current of 500 mA in total, which do not require any additional current for their basic functions (e.g. feedback unit). If the current requirement of the connected BiDiB nodes is greater, an additional power supply is required (e.g. BiDi-Power, art. no. 46-09116 or 46-09017).

The mc² automatically detects the connected BiDiB nodes. You can display technical information about the nodes and the structure of the BiDi bus on your system in the menu item "Operation / BiDiB" of the mc²-Toolbox.

Notice:

The total current of all external digital devices that are connected to the various interfaces of the mc² and do not have their own power supply must not exceed 1.2 A. Otherwise, the mc² automatically switches off the power supply for the external devices.

4.4. Connection of s88 feedback modules

Info

The mc² regularly initiates read-in cycles in which the levels of all registers in the clock are "passed through" from one register to the next to the central unit according to the bucket brigade memory principle. Like most modern central units, the mc² compares the read-in data with those of the previous read-in cycle and evaluates only the changed data or passes only the changes on to the control software.

Connection: RJ45 (according to s88-N)

Connection options

In total, you can directly connect up to 52 s88 feedback devices or s88-compatible modules (with max. 832 contacts) with a maximum total current consumption of 200 mA.

(→ Section 4.4.1)



- for direct connection of all s88 feedback modules with connections according to s88-N
- Connection of (older) s88 feedback modules with 6-pole pin headers via adapter S88-A-BR (item no. 44-09110) or S88-A-SR (item no. 44-09210)

! Notice:

Do not plug s88 bus cables into the BiDiB connector! This can cause severe damage to the mc².

! Note:

There are s88 feedback modules available with RJ45 connections where the contact assignments do not correspond to the s88-N standard. These are not suitable for connection to the mc². Damage to the mc² and/or the connected modules may occur during commissioning!

Configuration

Before starting operation, you must enter the number of connected s88 feedback modules.

→ Section 6.2.1 in the manual

→ Menu item "Operation / Detectors"

4.4.1. Power supply of the devices on the s88 bus

Background information

s88 modules draw the power they need for their operation via the bus line. The current is usually provided by the digital control unit (with s88 interface) or by the PC interface. It is not defined how much current the control unit or interface should provide for the s88 bus, nor how high the current consumption of the s88 modules may be.

Standard s88 modules have a very low current consumption (usually less than 10 mA). Our s88 modules (S88-1, S88-3, S88-4, S88-5 and S88-6) have a power consumption of less than 10 mA.

However, s88 modules from other manufacturers with special functions, for example, have a significantly higher current consumption (up to approx. 50 mA). This is due to the fact that additional components are required for the special functions (e.g. processors) and in some cases components are used that require comparatively high current.

Maximum 200 mA for the direct connection of s88 modules

The mc² provides up to 200 mA for supplying the devices on the s88 bus. The following problems can occur if the s88 modules consume more current:

- voltage drop in the s88 bus and therefore incorrect transmission of feedback signals
- tripping of the short-circuit fuse of the mc²
- in the worst case: damage to the control unit

If you require more than 200 mA current for your s88 modules, you will need an additional external power supply for the s88 bus (e.g. s88-Power, article numbers 44-09016 or 44-09017).

Note:

Use the technical data of your s88 modules to determine their power consumption. If the current consumption of all s88 modules is higher than 200 mA, you must use an additional external power supply. If the current consumption in the s88 bus is higher, your mc² may be damaged.

4.5. Connection of external boosters

If one booster is not sufficient to supply the layout or if the commands for vehicle and accessory decoders are to be output separately ("driving and switching separately"), you can connect additional external boosters.

4.5.1. Booster interfaces



MM: Märklin-compatible boosters

Connection: 5-pole, grid dimension 2.54 mm

CDE: DCC-compatible boosters

Connection: 3-pole, grid dimension 5.08 mm
(Connector plug included in delivery)



BiDiB: Boosters according to BiDiB specification

Connection: RJ45

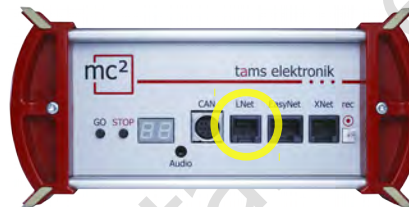

LNet: LocoNet booster

(only version 2-6 and 2-9 of the mc²)

Connection: RJ12

⚠ Note on the LNet interface of version 1 of the mc²:

Version 1 of the mc² has a pure LocoNet T(ool) interface via which no booster signals are transmitted. If a LocoNet booster is connected to the LNet interface of the mc², the control unit may be damaged during commissioning. LocoNet boosters must therefore be connected to one of the two interfaces for external boosters in version 1 of the mc².

Simultaneous use of different booster interfaces

If you want to supply separate layouts (sections) or if you use separate boosters, e.g. for driving and switching, you can use different booster interfaces at the same time. However, you cannot supply several booster sections of a layout mixed with different booster types (DCC-compliant, Motorola-compatible, BiDiB, LocoNet). Please refer to the examples in sections 4.5.3 to 4.5.5.

4.5.2. Recommendations for the use of external boosters

Warning:

If these recommendations are not followed, the mc² and other components of the digital control unit may be damaged (irreparably in the worst case) in unfavourable cases. When driving over the separation points between booster sections, equalising currents can occur which can damage the vehicles. In addition, faults in data transmission are possible, which can lead to accidents during operation.

Checking the use of a Power-Splitter

Firstly, you should check whether the use of a Power-Splitter (article numbers 40-20106 and 40-20107) is sufficient to supply additional sections of your layout. With the Power-Splitter, you can divide the output current of 6.5 or 9 A, which the integrated booster of the mc² can provide, into 2 to 3 booster sections with 2 to 3 A each.

Using the internal booster and external boosters

If additional external boosters are required, the internal booster of the mc² should preferably be used to supply an electrically isolated part of the system or to supply the accessory decoders separately. We only recommend our B-4 and B-6 boosters for combination with external boosters to supply booster sections whose separation points are crossed.

Use identical boosters (i.e. same manufacturer and same model)

Background: The voltage curve in the booster sections turns out to be all the more different the more different the boosters involved are constructed. This leads to equalising currents ("mini short circuits") when passing over the separation points, which in the worst case can cause damage to boosters, rails, wheels and sliders. In addition, there may be a shift in the voltage curves in the booster sections, with the result that the digital signals are not transmitted correctly. If vehicle decoders interpret driving commands incorrectly in this case, this can have fatal consequences.

Use boosters with regulated output voltage

Background: For boosters with unregulated output voltage, the actual voltage applied to the track depends on the current consumption in the booster section. Even with identical boosters, the track voltages in neighbouring booster sections can therefore differ significantly. Equalising currents ("mini short circuits") occur when passing over the isolating points. In addition, the actual track voltage is often significantly higher than the voltage recommended for the vehicles when power consumption is low.

Preferably use galvanically isolated boosters

Background: In digital layouts, the circuits for supplying the tracks and digital devices can either be galvanically (i.e. electrically) isolated from each other or connected to a common continuous earth. In practice, establishing a common continuous earth is prone to errors and therefore unreliable and risky, especially in larger layouts.

These risks are avoided by using galvanically isolated boosters. The signals are transmitted, but no electrical energy.

Use ground-related boosters with extreme caution

Background: An incorrectly implemented common through-ground can result in ground loops ("ground loops") and residual currents, which can cause malfunctions and, in the worst case, damage to all digital devices connected to the rails. (Unintentional) electrically conductive connections between the continuous earth and the internal earth of the mc² connected to the booster interface can cause serious damage to the mc².

 If you are using ground-referenced boosters, it is essential that you check the correct design of the common through-ground before commissioning. Make sure that the supply transformers are not connected to each other and/or to the rail earth! This also applies to transformers that supply purely analogue components (e.g. lighting).

tams elektronik

4.5.3. Example: Use of a Power-Splitter

For layouts with two or three booster sections with a current of 2 or 3 A each, the use of a Power-Splitter (article no. 40-20106 or 40-20107) is recommended. The Power-Splitter distributes the output current of 6.5 A (versions 1 and 2-6) or 9 A (version 2-9) of the internal booster of the mc² to either 2 or 3 booster sections.

With this solution, the output voltage and throughput time of the digital signals are absolutely synchronised in all connected booster sections. This ensures that neither short circuits nor errors in the transmission of the digital signals occur when passing over the separation points between the sections.

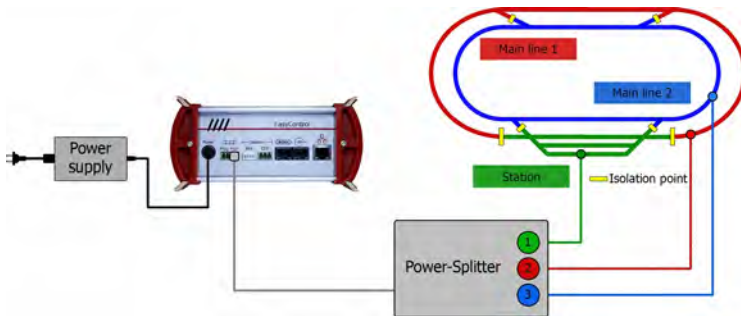

4.5.4. Examples: Separate "Driving" and "Switching"

Background

By default, the commands for controlling the vehicle decoders are sent continuously via the booster output of the control unit, while the commands for switching the accessory decoders are only sent when required. For this purpose, the transmission of the vehicle decoder commands is briefly interrupted and the accessory decoder commands are transmitted in the resulting gap. In PC-controlled (larger) layouts, this type of data transmission can lead to problems, e.g. if vehicle decoders receive stop commands too late and the locomotives overrun signals as a result.

Switching off accessory decoder commands

With the mc², the transmission of accessory decoder commands can be switched off at the booster outputs, separately for each of the following

- the DCC-compliant booster output
- the Märklin-compatible booster output
- the output of the internal booster ("Main") together with the BiDiB and LNet interface

Only vehicle decoder commands are transmitted at the outputs at which the accessory decoder commands are switched off; a delay in the transmission of drive commands due to the intermediate transmission of accessory decoder commands is therefore excluded.

"Driving" via the integrated booster and "Switching" via external booster

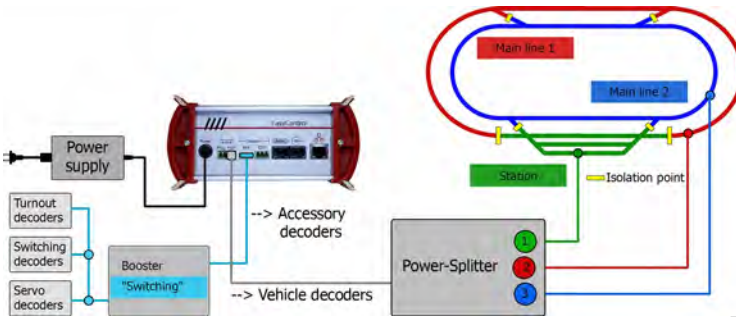

The vehicle decoders are supplied via the internal booster, for which the output of accessory decoder commands is switched off. The Power-Splitter distributes the current of the internal booster to 3 booster sections. The accessory decoders are supplied via an external booster, which is connected here to the Märklin-compatible interface. An external booster can be connected to the DCC-compatible interface in the same way. Note: The output of accessory decoder commands is switched on and off together for the output of the internal booster, the BiDiB and the LNet interface.

"Driving" via external booster and "Switching" via the integrated booster

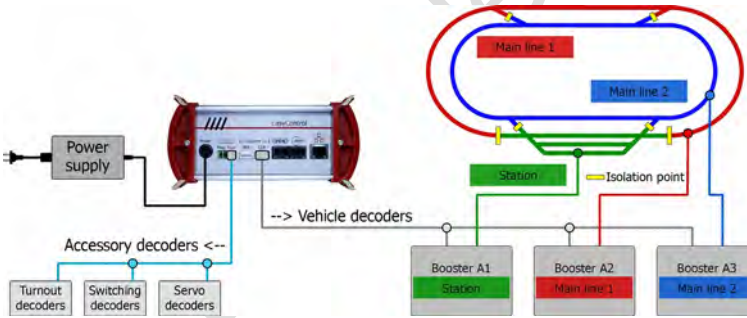

The internal booster supplies the accessory decoders. Three external boosters supply the vehicle decoders in the three booster sections of the layout whose separation points are crossed during operation. The external boosters must all be connected to the same interface (here the DCC-compatible interface). They can be connected to the analogue Märklin-compatible interface.

The external boosters must fulfil the following requirements:

- uniform types (i.e. same manufacturer, identical booster type)
- standardised, regulated output voltage. For boosters with adjustable track voltage, set the same values as for the mc².

Preferably use galvanically isolated boosters. If you use ground-related boosters, you must ensure that the common, continuous ground is correctly implemented (→ Section 4.5.2).

4.5.5. Examples: Additional boosters for driving operation

If different booster interfaces and booster types are to be used, special care is required during planning and implementation.

Different booster types for parts of the layout

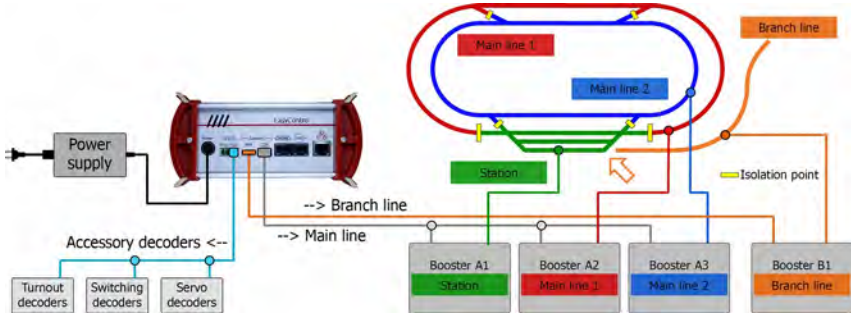

The internal booster supplies the accessory decoders. Three external boosters of type "A" supply the vehicle decoders in three booster sections of the layout, whose separation points are crossed during operation. They must all be connected to the same interface (here the DCC-compliant interface). Another external booster of type "B" (here connected to the Märklin-compatible interface) supplies the branch line, which is completely electrically isolated from the rest of the layout. Note: The use of a type "B" booster on another interface is only permitted for the supply of an electrically separate part of the system.

The external boosters for supplying sections whose separation points are crossed must fulfil the following requirements:

- uniform types (i.e. same manufacturer, identical booster type)
- standardised, regulated output voltage. For boosters with adjustable track voltage, set the same values as for the mc².

Preferably use galvanically isolated boosters. If you use ground-related boosters, you must ensure that the common, continuous ground is correctly implemented (→ Section 4.5.2).

Internal booster + external booster for parts of the layout

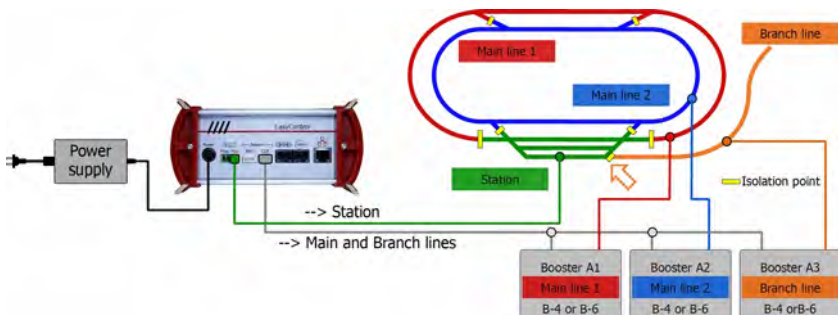

The internal booster supplies one section of the layout. Three external boosters supply the vehicle decoders in the three other booster sections of the layout whose separation points are crossed during operation. The external boosters must all be connected to the same interface (in this case the DCC-compliant interface).

Please note: In this constellation, the internal booster of the mc² can be severely damaged if the design of the external boosters differs significantly. We therefore only recommend the following boosters for this constellation:

- Booster B-4 (article numbers 40-19407, 40-19417, 40-1942x, 40-1943x) **or**
- Booster B-6 (article no. 40-19607)

Note: The track voltage can be set for the aforementioned boosters. Make sure to set the same value as for the mc².

Booster B-6 should preferably be connected to the BiDiB interface of the mc². This also applies if BiDiB is not otherwise used.

4.5.6. Assignment of the track connection to the rails

The assignment of the poles of the track connection to the two rails (or the rail and the centre conductor) is arbitrary as long as the internal booster of the mc² is sufficient to supply the layout. However, this does not apply if other external boosters are or will be connected to the layout. In this case, you must ensure that the polarity of all booster sections is identical!

⚠ Please note:
 If the polarity of the booster sections is different, considerable faults in data transmission and damage to the vehicles, rails and the track outputs of the external boosters and/or the internal booster of the mc² can occur when travelling over the isolating points!

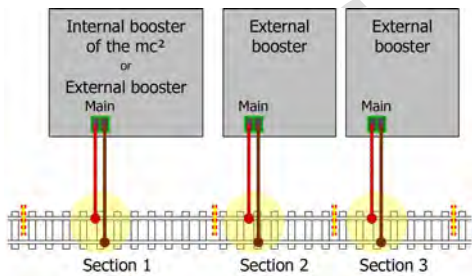

⚠ Please note:
 Carry out the separation points in such a way that the booster sections are permanently isolated from each other! Otherwise, short circuits may occur which could damage the track outputs of the boosters.

4.5.7. Configuration

Before you start system operation, you must configure the boosters, i.e. set them to match the nominal size of your system.

- Section 5.5 in the manual
- Menu item "System / Boosters"

4.6. Connection to the audio output

Info

The audio output of the mc² is technically correctly designated as a "line-out output". The line-out signal at the output has a high sound quality.

At present (as of march 2024), the output is not yet supported by the software of the control unit. With a later software version, it will be possible to store and retrieve background sounds in the mc². It is also planned to call up situation-specific sounds together with the switching of functions.

Later software versions will be available for free download from the Tams Elektronik website at www.tams-online.de.

For the connection of

- Active speakers (e.g. typical PC speakers)
- Amplifiers in combination with passive loudspeakers

The connection is made via 2.5 mm stereo jack plugs.

tams elektronik

tams elektronik

5. Configuring the system (Submenu "System")

In the submenu "System" you make all the settings that are necessary to adjust your mc² for operation with your layout. The explanations for the input fields open when you click on the symbol .

5.1. System Info

In this menu item you can get an overview of the essential data of your digital central unit:

- Hardware and software status of your mc²
- Serial number, IP address and MAC address of your mc²
- Flash and RAM allocation
- Status when switching on: STOP or GO
- Supply voltage
- Temperature of the mc²
- Track voltage: This value is set in the menu item "System / Boosters" according to the nominal size of the layout.
- Current / maximum current: The maximum current is set in the menu item "System / Boosters". If the maximum current is exceeded, the integrated booster of the mc² is automatically switched off.
- Connected input devices: All input devices connected to the interfaces for EasyNet, XpressNet, LocoNet or the CAN bus are displayed. Information on feedback devices connected to the mc² can be queried in the menu items "Operation / Detectors" and "Operation / BiDiB".

Info: Flash and RAM

"Flash" refers to the internal permanent memory of the mc², in which all data is stored that is retained after switching off, e.g. the configuration, the locomotive database or audio files. An occupancy of up to 90 % is not critical. It can be exceeded, for example, if a large number of audio files are stored.

"RAM" refers to the internal working memory of the mc², in which all data generated during operation are stored. An occupancy of up to 90 % is not critical. If this value is permanently exceeded, there may be a defect in your mc². In this case, please contact the Technical Hotline.

Info: Supply voltage

The supply voltage is 24 V in normal operation. If it is below 22 V, the power supply unit is overloaded. This case occurs, for example, when the output current of the integrated booster reaches the maximum of 6.5 A and at the same time many additional devices are connected to the mc² which are supplied via the bus lines. In this case, you must reduce the current in the booster circuit and/or the number of additional devices connected. In case of a permanent overload, the power supply unit switches off automatically and switches on again after the overload has been eliminated (hiccup mode).

Info: Temperature

Heating of the central unit during operation is normal and harmless. Under permanent full load, i.e. if the integrated booster supplies more than 6 A of current for a longer period of time, the temperature can reach up to 75 °C.

! Notice:

To prevent the mc² from overheating, you must ensure that a distance of at least 20 cm to surrounding surfaces is maintained on the side surfaces and the top and rear of the mc².

If a high temperature is reached at low load, the mc² probably has a defect.

! Notice:

If you notice overheating and suspect a defect in the mc² as the cause, disconnect the central unit from the supply voltage immediately. **Fire hazard!** Send the mc² in for testing.

Saving and loading system settings

The configurations for the boosters, the protocols, the accessory decoders and the feedback modules are saved in the file with the system settings. For the vehicle decoders, only the standard format and purging are saved.

You can save and load the vehicle database ("locomotive list") separately in the menu item "System / Vehicles".

Tip: When you have finished configuring your mc², you should save the system settings. You can then load the settings again if the internal fixed memory of the mc² (the so-called "flash") is damaged, e.g. in the event of a power failure.

5.2. Vehicles

⇒ Management of the vehicles

Standard format

At delivery, the DCC format with 28 speed steps is set as standard, i.e. this protocol is applied to the track by default. Vehicle decoders with the standard format can therefore be controlled directly, vehicle decoders with different formats only if they have been created in the locomotive list beforehand. The setting of the standard format is taken over as the default setting in the locomotive list.

Standard format	Vehicle decoders, which can be controlled directly	Notes
MM1/14 MM2/14 MM2/27A MM2/27B	all MM-decoders and mfx-decoders If addresses >255 are selected, the mc ² automatically switches to DCC format, for addresses >10,239 to m3 format.	As soon as the m3 signal is present on the track (e.g. after accidentally entering a locomotive address >10,239), mfx vehicle decoders react exclusively to m3 commands and no longer to MM and/or DCC commands.
DCC/14 DCC/28 DCC/126 DCC/SDF	all DCC decoders and mfx decoders that support DCC If addresses > 10,239 are selected, the mc ² automatically switches to the m3 format.	
m3/126	mfx decoders that have been assigned an m3 address	Assignment of the m3 address: → System / Vehicles / m3 → Operation / Programming / m3

Locomotive list

The database with your vehicles (in short "locomotive list") is a central part of your digital control. Assigning names to your vehicles is not mandatory, but can be very helpful if the decoder address has been forgotten or accidentally changed.

Function icons

Various icons are stored, which illustrate the numerous possible functions of vehicle decoders (lights, couplers, smoke generators, sounds). Each icon is displayed in two versions, showing the function in switched on or switched off state.

Tractions

The control of locomotives in tractions is only possible if the same number of speed steps is assigned to the decoders. Tractions with vehicle decoders with different data formats are possible. Possible combinations:

- DCC and Motorola decoders with 14 speed steps
- DCC decoders with 28 speed steps and Motorola decoders with 27 speed steps
- DCC decoders with 128 speed steps and mfx decoders with 126 speed steps

If you form tractions of locomotives with different driving directions, you can invert the driving direction for one locomotive. In operation, this locomotive will then travel backwards (or vice versa) when travelling forwards.

Tractions react together under all decoder addresses of the traction to driving commands and the command to change direction. To switch the functions, the locomotive must be called up under its respective address.

Further settings in the "Vehicles" menu item

- Purging: You can specify that decoders that have not received any new driving or switching commands within the set time (1 to 20 minutes) are removed from the refresh.
- Lnet Dispatch: LocoNet hand controllers are used to control one specific vehicle. If you have connected such a hand controller to the LNet interface of your mc², assign it "its" decoder address here.

5.3. Accessories

⇒ Management of the accessory decoders

In this menu item you set how your accessory decoders are to be controlled by default:

- Standard format (MM or DCC)
- Minimum and maximum switching time
- Number of repetitions of accessory decoder commands
- Address assignment: according to standard or deviating from the standard

You can specify for which accessory decoder addresses (turnouts addresses) exceptions to the set standard format should apply.

BiDiB accessory decoders

The list is limited to displaying the BiDiB nodes that fulfil the requirements for the "Accessory" class defined in the BiDiB specification.

The display of all BiDiB nodes, including their assignment to the levels and a list of their properties, can be found in the menu item "Operation / BiDiB". There you also have the option of triggering an Identify command and performing a reset. → Section 6.2.4

The outputs of BiDiB accessory decoders cannot be switched with external control devices (e.g. manual controllers) by default. In the "BiDiB" window, you can assign addresses to the outputs of the BiDiB accessory decoders on your layout. These addresses are treated like turnout addresses that react to turnout setting commands entered on external control devices.

Input field "Remarks"

Tip: The input field "Remarks" is intended for your notes on the accessory decoders. You can enter free texts and save them in external files or load texts from external files.

5.4. Protocol

⇒ Optimisation of the data transmission

With the default setting "normal", a safe and sufficiently fast transmission of digital data between the mc², the decoders and the feedbacks is guaranteed for many installations.

In the help that opens after clicking on the symbol , you will find detailed explanations of what is hidden behind the various terms. Basically, you should always set the default values if you are not sure what deviating settings will do. In the following cases you should check the settings and adjust them if necessary:

Use of Motorola decoders

Change the MM signal pause setting if

- locomotives with Motorola I decoders do not react to driving and switching commands or show a bad driving behaviour during driving operation
- if function decoders for the Motorola format (e.g. in function models) do not react to digital commands.

No use of RailCom

In this case, switch off RailCom and NOP. This switches off the RailCom gap and suppresses the sending of NOP commands, thus increasing the speed of data transmission to the decoders.

Control of mfx decoders

You must activate m3 (and assign an m3 address to the mfx decoders) to be able to control them with the m3 format. Note: As soon as the m3 signal is present on the track (e.g. after accidentally entering a locomotive address > 10,239), mfx vehicle decoders react exclusively to m3 commands and no longer to MM and/or DCC commands.

If you prefer to control mfx decoders in DCC or MM format, you must deactivate m3.

5.5. Boosters

⇒ Settings for the integrated and external boosters

With the setting of the nominal size, standard values for track voltage, maximum current, short-circuit sensitivity and inrush time are preset, with which a safe operation on your layout is guaranteed.

In the help that opens after clicking on the symbol , you will find explanations of what is hidden behind the various terms. Basically, you should set the default values if you are not sure what deviating settings will cause.

Setting options for the integrated booster

- Track voltage at the output
- Maximum current (cut-off current)
- Short-circuit sensitivity
- Inrush time
- Signal routing

The settings for the integrated booster also apply to boosters connected to the BiDiB interface.

Notice:

Too high a track voltage and/or too high a cut-off current can cause damage to vehicles or tracks. You are on the "safe side" if you set the nominal size of your layout in the menu item "System / Boosters" and thus preset the usual values.

Setting options for the external boosters

- Short-circuit sensitivity
- BiDiB booster: The settings control the switch-off behaviour of the control unit if at least one booster is connected to the BiDiB interface.
- Signal routing: The settings are made separately for DCC-compliant and Märklin-compatible boosters.

Info: Signal routing

By default, the commands for controlling the vehicle decoders are sent continuously via the booster outputs of a digital central unit, the commands for the accessory decoders only when required. For this purpose, the transmission of the vehicle decoder commands is briefly interrupted, the accessory decoder commands are transmitted in the resulting gap.

In PC-controlled (larger) layouts, this type of data transmission can lead to problems, e.g. if vehicle decoders receive stop commands too late and the locomotives overrun signals as a result. To avoid this, in (larger) PC-controlled layouts the output of commands for vehicle and accessory decoders is separated ("separate driving and switching").

With your mc² you can switch off the output of the accessory decoder commands separately for the internal booster, the DCC-compliant and the Märklin-compatible booster output. The setting for the internal booster also applies to boosters on the BiDiB interface. At the booster output where the output of accessory decoder commands is switched off, only vehicle decoder commands are then transmitted. For the output of the accessory decoder commands then use another booster output.

tams elektronik

6. Operation with the mc²

6.1. Operating and display elements

The mc² has a STOP and GO button with which you can trigger essential functions directly on the unit. To switch the track voltage on and off, you can alternatively click on the photo of the mc² on the start page ("HOME") of the mc²-Toolbox.

The display on the front provides you with essential information about the operating status of your mc². In addition, the RGB LEDs built into the housing change colour and thus visibly indicate the operating status from afar.

6.1.1. STOP and GO buttons

Button	Duration	Function	Shown in the display	Colour of the RGB LEDs
GO	short	Switching on track voltage	0.0 or current power consumption	green
STOP	short	Switching off track voltage	St.	red
GO GO, GO, GO, ...	long short, short, short, ...	Reading out the IP address The individual digits of the IP address are retrieved by pressing the "GO" key several times. → Section 2	IP 12 3.4 56. 78 9.1 23	red
STOP	long	Sending BiDiB-Identify for the mc ² (→ registration of the mc ² with the PC control software)	St.	blue circulating
GO + STOP	long	Reset ausführen	rE	blue flashing + white swelling
off*		Configuration incl. deleting the locomotive list and resetting to factory settings	Fr	red
GO + on*	when switching on			
off*		Starting recovery software → Section 7	Dots flash alternately	violet
GO+ STOP + on*	when switching on			

* **off**: Switching **off** the power supply

* **on**: Switching **on** the power supply while holding down the button(s)

6.1.2. Display and RGB-LEDs

Shown in the display	Colour of the RGB LEDs	Meaning
0.0 to 6.5 or 9	green	current current consumption [A] The track voltage is switched on.
St.	red	Stop. The track voltage is switched off.
td	green	"Test Drive". In test mode you can control and test vehicle and accessory decoders on the programming track with the virtual control units HandControl.prog. and FunctionControl.prog.
SH	red violet flashing	"Short Circuit" / short circuit during operation. Troubleshooting → section 8.2
ot	yellow orange red flickering	"Overtemperature" / Overheating Troubleshooting → Section 8.2
rE	blue flashing + white swelling	A reset is performed.
St.	blue circulating	Stop / The track voltage is switched off. If the STOP button was previously held longer, the command for the BiDiB Identify for the mc ² is sent.
PA	no colour change	Pairing. Control software is loaded for the first time on a connected PC or mobile terminal
IP 12 3.4 56. 78 9.1 23	no colour change	IP address The individual digits of the IP address are retrieved by pressing the "GO" key several times. → Section 2
Pf	red	"Power failure". The input voltage is below 22 V. Disconnect the control unit from the supply voltage immediately! Troubleshooting → section 8.3

Shown in the display	Colour of the RGB LEDs	Meaning
LP	red	"Low Power". The input voltage after switching on is below 22 V. Disconnect the control unit from the supply voltage immediately! Troubleshooting → section 8.3
Fr	red	The configuration is deleted and the mc ² is reset to the factory settings.
1...99 or ---	violet circulating	An update is being carried out. The digits indicate the progress in %. During writing, the progress display is interrupted.
[]	blue flashing + white swelling	The update is being processed and completed.
E + digit	no colour change	An internal error has occurred. Please make a note of the digit(s) and contact the hotline.
Dots flash alternately	violet	The recovery software has been started. → Section 7

Setting options for the RGB LEDs

On the "Home" page of the Toolbox, you can activate and deactivate the following functions of the RGB LEDs:

- Light effects ("boredom mode")
- Dim light. If the function is activated, in standard mode the green and the red lighting (as an indication of switched on or switched off track voltage) is reduced after the LEDs light up briefly.

6.2. Submenu "Operation"

In this submenu you can do all the things that occur during operation of you layout:

- Controlling vehicle and accessory decoders
- Reading out and programme decoders
- Checking feedback modules
- Reading out and displaying system messages
- Setting the model time
- Store and display the track diagram of your layout in the "Signal box" and set up and start automated processes for individual trains

The explanations of the input fields are opened when you click on the symbol .

6.2.1. Feedback

- ⇒ Overview of all connected feedback devices (s88, CAN, BiDiB and LocoNet)
- ⇒ Management and test of s88-, CAN- and LocoNet feedback modules

s88-, CAN- and LocoNet-feedback modules

In this menu item, all feedback devices that generate simple occupancy messages are recorded. Enter how many modules you have connected to the s88, CAN and LNet interface. Otherwise, the feedback modules will not be taken into account in the evaluation of the busy signals. A module with 16 inputs is considered to be one. Modules with fewer inputs (e.g. 8) are evaluated proportionally (e.g. as ½ module).

You can also check the occupancy messages of the connected s88, CAN and LocoNet feedback modules and thus detect faulty messages. Differences between the display and the actual state of an input indicate problems with the data bus, errors on the feedback module or on system parts connected to the feedback module.

You can set the type of display

- static or dynamic
- for one or more modules

BiDiB feedback modules

The list is limited to the display of BiDiB nodes that meet the occupancy class requirements defined in the BiDiB specification.

The display of all BiDiB nodes including the representation of their assignment to the levels as well as the listing of their properties can be found in the menu item "Operation / BiDiB". There you also have the option to trigger an Identify command and to perform a reset. → Section 6.2.4

In order to be able to evaluate the occupancy messages of BiDiB feedback devices with programmes that do not support BiDiB (e.g. the mc² internal "signal box" or programmes based on the p50x protocol), you can assign address ranges to the inputs of the BiDiB feedback devices on your layout. The occupancy messages of the BiDiB feedback units are then transferred internally to the s88 bus.

6.2.2. Programming

⇒ Programming and reading vehicle and accessory decoders

⇒ Testing vehicle and accessory decoders

In this menu item you have access to all common programming types for vehicle and accessory decoders:

- Programming on the main track or programming track
- Data formats: DCC, m3 and Motorola

With the virtual HandControl.prog on the side you can directly check the settings of decoders on / at the programming track.

Note that main track programming (POM) and programming on the programming track (PROG) and reading out the configuration variables (CVs) is not possible for all decoder types and data formats.

		Vehicle decoders	Accessory decoders Basic*	Accessory decoder Extended*
DCC	read out	POM + PROG	POM + PROG	POM + PROG
	program	POM + PROG	POM + PROG	POM + PROG
MM	read out	PROG: determine address	assign addres*	---
	program	PROG	---	---
m3	read out	PROG: determine UID	---	---
	program	PROG: assign address	---	---

* Background info on programming accessory decoders

According to RailCommunity standard RCN-214, there are two ways of programming DCC accessory decoders:

- Basic is the most common type of programming. Unless otherwise stated in the accessory decoder instructions, assume that "Basic" is the type of programming used for this decoder.
- Extended is mainly used for programming signal decoders. Please check in the manual if the decoder supports this type of programming.

With many Motorola accessory decoders it is possible to assign them their address by entering a turnout address from a block of 4. To do this, they must be put into programming mode, e.g. by attaching a jumper or pressing a button. With the mc² you can directly assign an address to these Motorola accessory decoders when you connect them to the programming track.

HandControl.prog

The HandControl.prog and the FunctionControl.prog have almost the same functionality as the standard versions of the virtual controllers and are especially used for testing decoder settings. However, in test mode (display "td" in the display of the mc²) you can only control vehicle and accessory decoders on / at the programming track.

- HandControl.vi → section 6.3.1
- FunctionControl.vi → section 6.3.2

The following functions differ from the standard version of the virtual HandControl:

- F** Change to FunctionControl.prog
- Y Γ** Change of the interface for switching accessory decoders at the programming track
- M** Change to HandControl.vi (the standard version of the virtual HandControl)

Testing accessory decoders

The diagram shows the HandControl.prog interface. At the top, it says "HandControl .prog". Below that is a yellow display area showing "W-Nr: 12", "esc = | |", and "<- = | /". Below the display are two buttons: "=" and "=". Underneath is a blue slider with a white knob. Below the slider is a button labeled "0". Below that is a numeric keypad with buttons 1-9, a "stop" button, and a "go" button. To the right of the numeric keypad are function keys: "F", "Y Γ", and "M". At the bottom, it says "tams elektronik" and "EasyControl".

Callouts on the left side point to specific parts of the interface:

- Turnout adress → points to the "W-Nr: 12" display.
- Turnout position → points to the "esc = | |" display.
- Turnout "straight ahead" → points to the "esc" button on the keypad.
- Turnout "branch" → points to the "<-" button on the keypad.

Text on the right side explains the operation:

To select the turnout address, enter the address via the number fields. Afterwards you can switch between the two turnout positions with the buttons **esc** and **<-**

6.2.3. Messages

⇒ Read out and display system messages

The various messages are particularly helpful when checking the function of the connected components and finding the causes of malfunctions. Tip: Before contacting the Technical Hotline about problems with your digital control, connect your mc² to a PC or tablet. The hotline staff may ask you to read out certain types of messages.

6.2.4. BiDiB

⇒ Display of all connected BiDiB nodes, their assignment to the levels and their properties

⇒ Identify and Reset

The list shows all connected BiDiB nodes and their assignment to the levels. According to the BiDiB specification, the mc² is a node and fulfils the tasks of a BiDiB interface and a track output device. The integrated booster also reports its data via the BiDi bus. The mc² is therefore displayed as a BiDiB node in the top level - regardless of whether other BiDiB components are present.

The properties of the BiDiB nodes are listed in the info field:

- the address
- the manufacturer
- the type designation
- the name and
- the features

After right-clicking on the name of a node, a window opens and you can send an Identify command or reset the node.

6.2.5. Control

⇒ Calling the virtual HandControl.vi

The HandControl.vi is similar to the "real" HandControl.2. You can select and control vehicle decoders directly with it. From the HandControl.vi you can also reach the other virtual control units

- FunctionControl.vi for controlling one vehicle decoder
- DriveControl.vi to control up to four vehicle decoders simultaneously
- SwitchControl.vi for switching accessory decoders
- LocoControl.vi for controlling up to nine vehicle decoders

For the functionality and operation of the virtual control units → section 6.3

6.2.6. Model time

⇒ Controlling the layout according to timetable

For the control of your layout according to a timetable this menu item allows you

- to start and stop the model time
- to define the start time
- to define the time factor: Depending on the setting, the model time runs up to 60 times faster than the real time.
- to select the design

Alternatively, you can set the model time in your PC control software.

Tip: Use a smartphone or tablet that you position in a place visible from all areas of your layout to display the model time. You can choose between four different designs for the display of the model time.

6.2.7. Signal box

⇒ Track diagram, automatic train control

In the "Signal box" you have the option of

- displaying the track diagram of your layout
- displaying and changing the current position of the turnouts on the screen
- displaying the occupancy status of signalling sections
- setting up automatic train control for a locomotive address, i.e. defining a route that is to be run automatically.

For the functionality and operation of the signal box → Section 6.4

6.3. Virtual control devices



The virtual control devices enable e.g. the use of tablet(s) or smartphone(s) as external control units or tests during configuration or programming on the PC screen. Depending on the operating situation, you can choose between four different user interfaces and switch back and forth:

- HandControl.vi with a user interface based on the HandControl.2
- FunctionControl.vi for controlling **one vehicle decoder**
- DriveControl.vi to control up to **four vehicle decoders** simultaneously
- SwitchControl.vi for switching **accessory decoders**
- LocoControl.vi for controlling up to **nine vehicle decoders**

6.3.1. HandControl.vi

Calling up the vehicle address

Proceed as follows to select a locomotive or function decoder for driving and/or switching:

- Click on the locomotive symbol .
- Enter the decoder address by clicking on the number fields.
- Confirm the entry with .
- The "Display" shows the address, the data format, the vehicle name, the current speed step and driving direction as well as the switched-on functions.
- To delete an incorrect entry, click on .



Driving a locomotive

For the locomotive shown in the "display", you can

- change the speed level with the slider and
- change the direction of travel by clicking on the direction switch.





The current power consumption is shown in the bar below the display.

Switching functions

 he selected vehicle, you can switch the functions F0 to F9 on and off directly by clicking on the number fields. To switch functions up to F32, you must switch to FunctionControl.vi by clicking on . All switched-on functions up to F20 are shown in the "Display".

Switching to other virtual control units or to the menu

You can switch directly to the other virtual control units or back to the menu.

-  Double-click → LocoControl.vi to control up to nine vehicle decoders
-  FunctionControl.vi to control the selected vehicle
-  SwitchControl.vi to switch accessory decoders
-  DriveControl.vi to control up to four vehicles
-  Menu of the mc²-Toolbox, Default setting: operation / programming

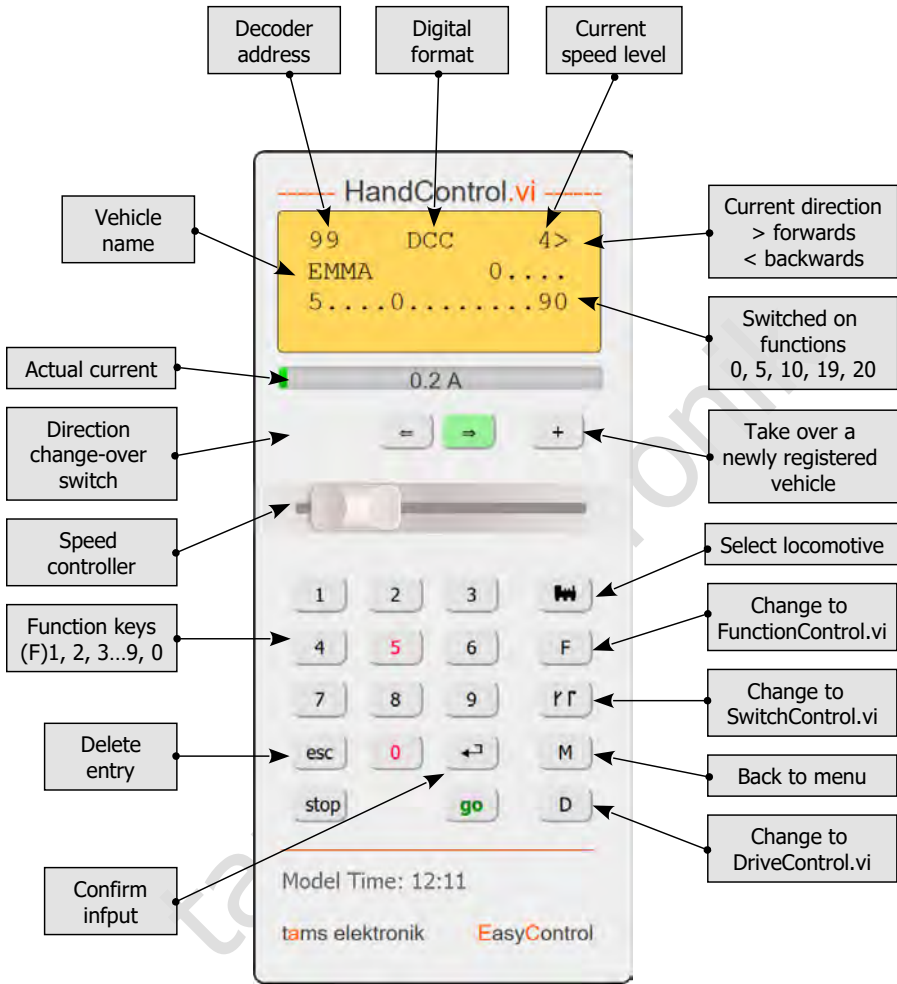

6.3.2. FunctionControl.vi

With the FunctionControl.vi you can control the vehicle decoder that you have previously called up with the help of the HandControl.vi. While you can only switch the functions F0 to F9 on and off with the HandControl.vi, the FunctionControl.vi allows you to switch the functions F0 to F32. If you have assigned icons to the functions, these are displayed instead of the function numbers.

You can switch between displaying the speed controller on the left or right side of the user interface by clicking on the field .

From FunctionControl.vi you can switch directly to SwitchControl.vi to switch accessory decoders or go back to HandControl.vi.

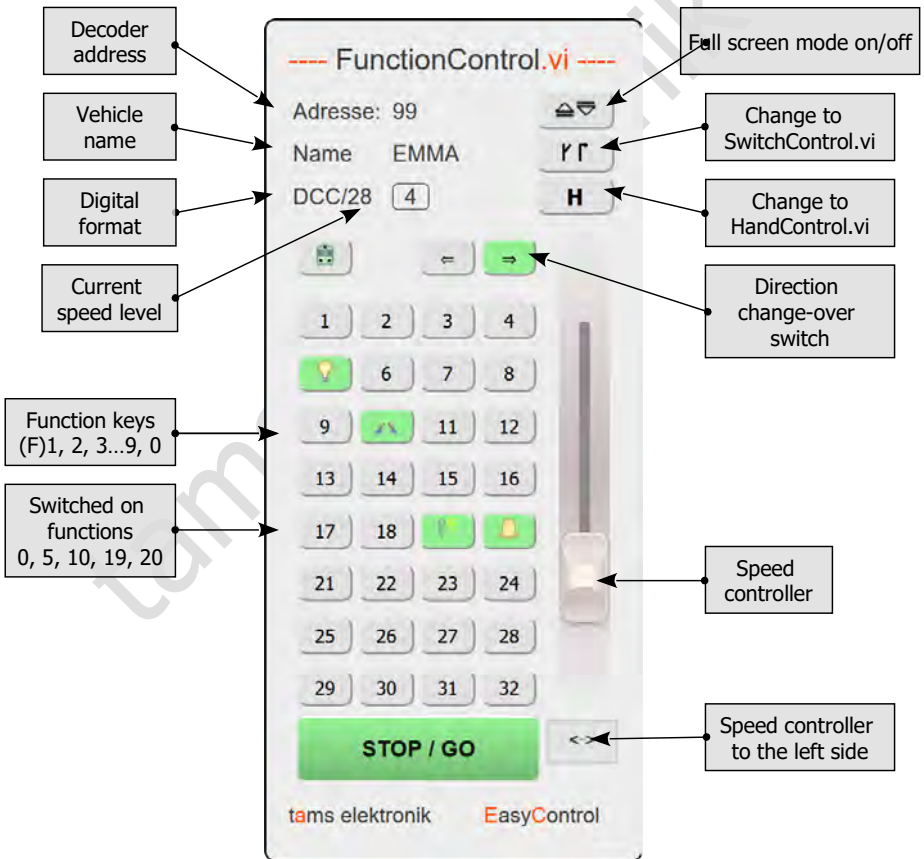

6.3.3. DriveControl.vi

Select up to four vehicle decoders that you want to control. To do this, enter the addresses directly in the input fields or click the arrow keys to increase or decrease the set address by 1 each.

You can change the speed level for the selected vehicle decoders using the sliders, change the direction of travel and switch the F0 function on and off.

You can go from DriveControl.vi directly back to HandControl.vi.

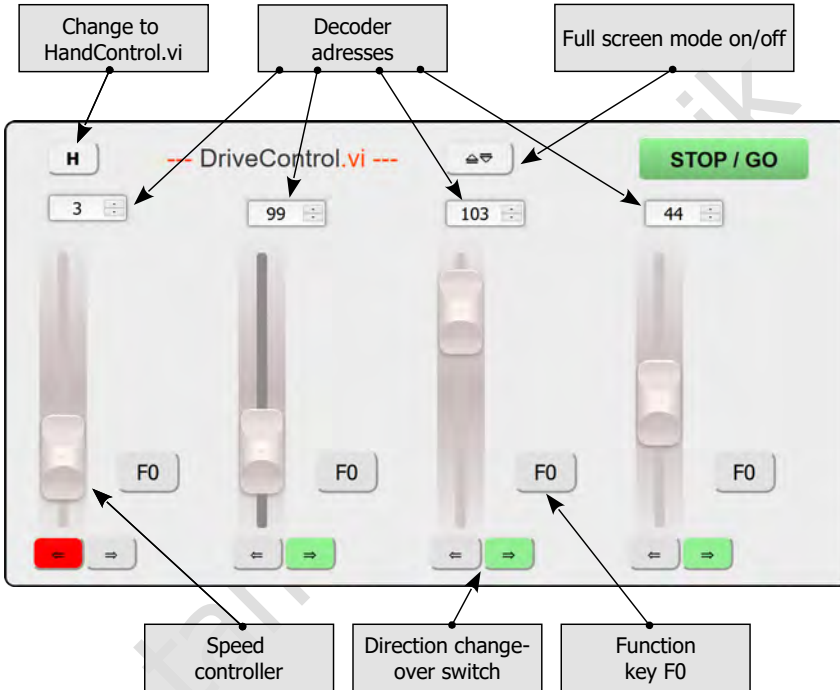

6.3.4. SwitchControl.vi

The SwitchControl.vi allows you to switch accessory decoders up to turnout address 2048. To switch to the next 16-number block, click on ▲ or ▼ . To skip several blocks of 16 numbers, use the double arrows.

You can switch between displaying the speed controller on the left or right side of the user interface by clicking on the field <> .

From SwitchControl.vi you can go directly to FunctionControl.vi to control the last vehicle called up or go back to HandControl.vi.

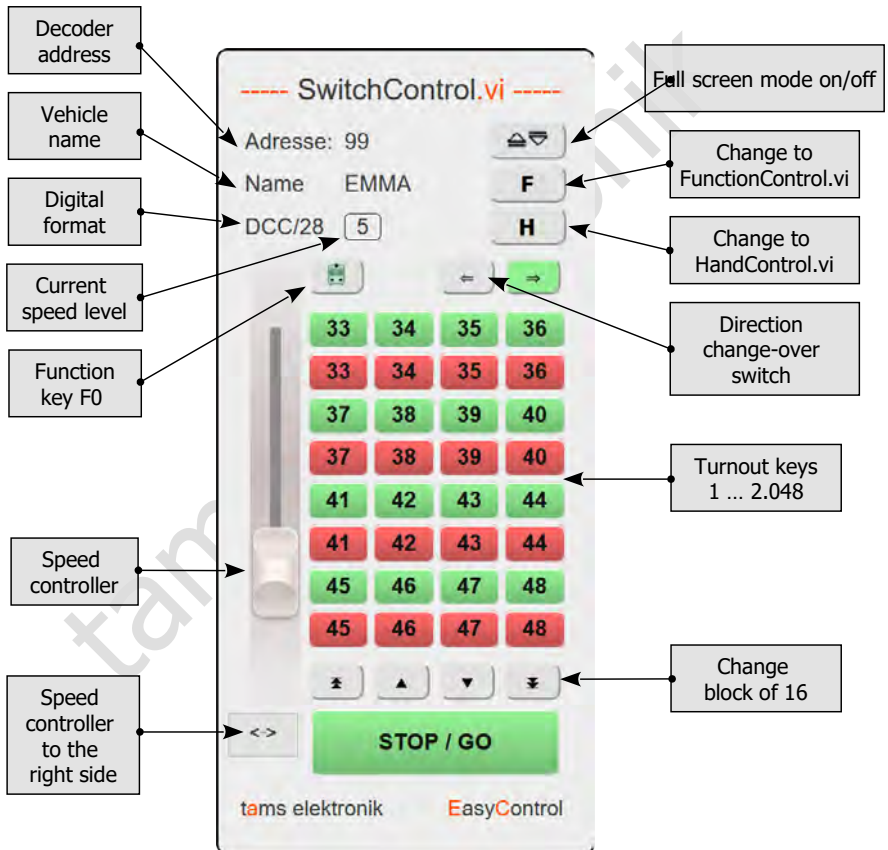

6.3.5. LocoControl

LocoControl.vi is an alternative user interface for controlling vehicle decoders (instead of HandControl.vi or FunctionControl.vi).

LocoControl.vi gives you access to up to nine vehicle decoders that you have selected from the locomotive list. To select a vehicle decoder from your locomotive list, double-click on the field at the bottom of the user interface.

Single-click on the field with the decoder address to select the decoder for which you want to enter travel and switching commands. The address, data format and number of speed levels of the selected decoder are displayed, as well as the name, the principle symbol and the symbol (if available). You can change the speed level using the slider, change the direction of travel and switch the functions on and off. Depending on the setting, the functions are displayed as numbers or symbols in the locomotive list.

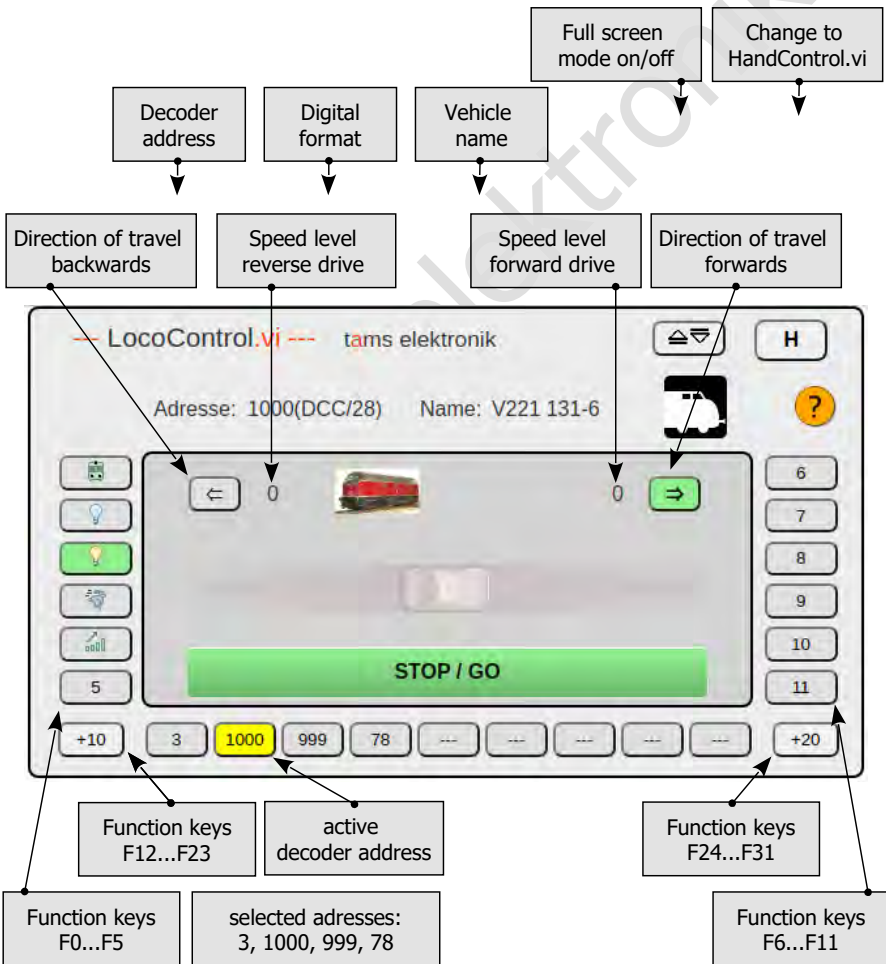

6.4. Signal box

In the "Signal box" you have the option of

- displaying the track diagram of your layout
- displaying the current position of the turnouts and changing them on the screen
- displaying the occupancy status of signalling sections
- setting up an automatic train control for a locomotive address, i.e. defining a route to be travelled automatically.

Note: The options offered by the signal box in the mc² Toolbox are limited compared to complex PC control programmes. The Signal box is not designed as an alternative to PC control software, but rather for use with small layouts or small sections of larger layouts that are usually controlled manually.

6.4.1. Track diagram

The track diagram that you create in the signal box comprises a maximum of 20x20 fields on which you can arrange the track and points symbols as well as free text. You can save as many different track diagrams as you like on your PC and load them again. When saving, the current track diagram is also saved in the mc², overwriting previous versions. After calling up the signal box, the track diagram saved in the mc² is automatically loaded.



Example of a track diagram: The position of the turnouts is displayed, the occupied signalling sections are marked. For signalling sections of local RailCom detectors, the addresses of the vehicles with RailCom-capable vehicle decoders are also displayed.

Position of the turnouts and switching turnouts

After you have assigned the associated turnout addresses to the turnouts, you can change the turnout position by clicking on the turnout symbols. The change of the turnout position is implemented immediately.

If you call up the signal box again or load a previously saved track diagram, the turnout position that was set when saving is displayed. This may not correspond to the actual position of the turnouts on the layout. A corresponding setting command in the signal box of the Toolbox sets the turnouts according to the display in the track diagram.

Display of the occupied track sections

As soon as you have assigned the numbers of the signalling sections (= contact numbers) of the s88, CAN and/or LocoNet feedback modules to the track symbols, occupied sections are displayed in orange. Occupancy messages from BiDiB feedback modules are also displayed, provided that the modules have been assigned an address range in the "Operation/Detectors/BiDiB" menu item of the Toolbox.

Whether the track occupancy messages are also displayed after loading the track diagram when the track voltage is switched off depends on the type of feedback module.

In addition, the addresses of vehicles with RailCom-capable decoders are displayed in sections that are monitored by a local RailCom detector. The prerequisite for this is that the RailCom detector transmits its messages to the mc² via BiDiB and has been assigned an address range.

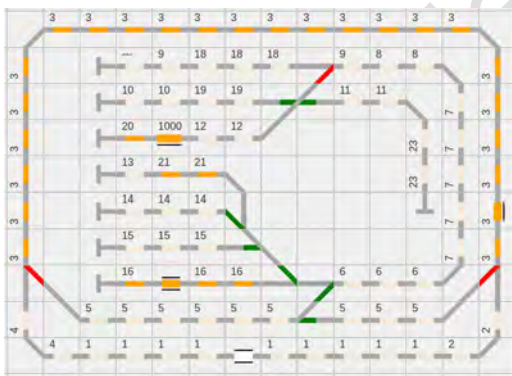

The assigned numbers of the signalling sections (= contact numbers) can be shown or hidden as required. It is advisable to show the numbers in order to check whether the correct numbers have been assigned to all sections.

6.4.2. Automatic train control

You can define a "timetable" for each vehicle decoder address as the basis for automatic operation and save it in a file together with the track diagram. You define the route by defining the start contact, any number of route contacts and the end contact as well as the position of the turnouts. The turnout(s) is/are set as soon as the train has passed the contact that is inserted in the timetable directly in front of the turnout(s) and the waiting time set for the contact has expired.

You can also set the following parameters for the contacts, which are implemented in the order listed once the respective contact has been reached:

	Parameter	Start contact	Route contact(s)	End contact
1	Delay time	no setting possible	X	X
2	Waiting time (= speed level 0*)	no setting possible	X	X
3	Functions (on/off)**	X	X	X
	Direction of travel	X	X	no setting possible
	Speed*	X	X	no setting possible

* The new speed and speed level 0 are implemented with the acceleration and brake delay set for the decoder.

** The turnouts are set at the same time as the vehicle functions, which are inserted in the timetable directly after the contact (before the next contact).

Please note the following special features:

Automatic train control is intended to control automatic operation on a **separate route** that is to be travelled by **one train**. An example is shuttle train operation on a branch line.

To prevent disruptions and accidents, you must therefore take the following points into account when setting up automatic train control:

- Occupied sections are not safeguarded by the automatic train control. The locomotive can therefore drive into occupied sections in automatic mode. **Danger of collision!**
- The turnout(s) is/are set as soon as the train has passed the contact that is inserted in the timetable directly in front of the turnout(s) and the waiting time set for the contact has expired. If several turnouts are inserted in the sequence between two contacts, **all** turnouts are set as soon as the locomotive has passed the first contact and the waiting time set for the first contact has expired.
- The automatic train control does not recognise whether the vehicle for whose locomotive address the automatic system has been set up is at a contact or another (current-consuming) vehicle. If the locomotive for which automatic train control has been set up is located at a different point in the layout, it will move off at the speed and direction of travel set for this contact.

Effects of the settings on the speed

Example 1	Start contact	Route contact	Endcontact
Delay:	---	0/10 seconds	0/10 seconds
Waiting time:	---	0 seconds	0 seconds

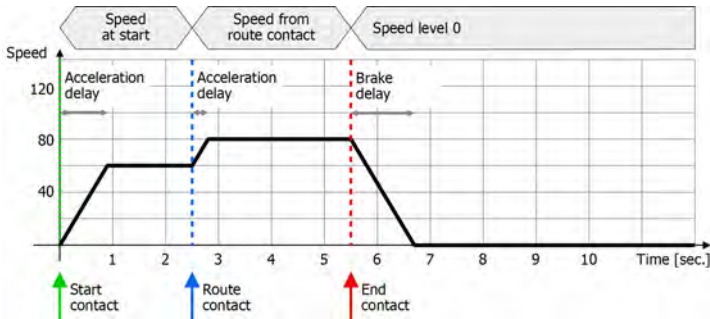

Note: Acceleration and brake delay are parameters of the vehicle decoder.

Example 2	Start contact	Route contact	Endcontact
Delay:	---	5/10 seconds	10/10 seconds
Waiting time:	---	0 seconds	0 seconds

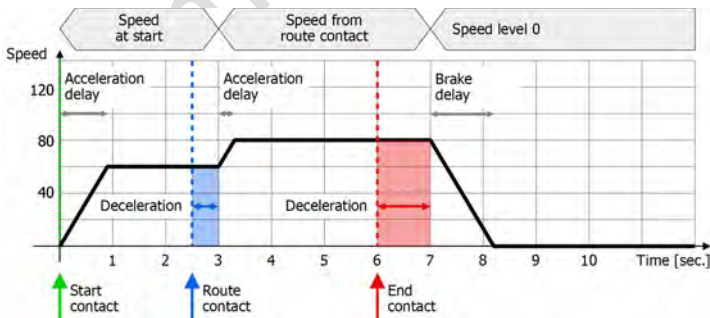

Note: Acceleration and brake delay are parameters of the vehicle decoder.

Example 3	Start contact	Route contact	Endcontact
Delay:	---	0/10 seconds	0/10 seconds
Waiting time:	---	2 seconds	2 seconds

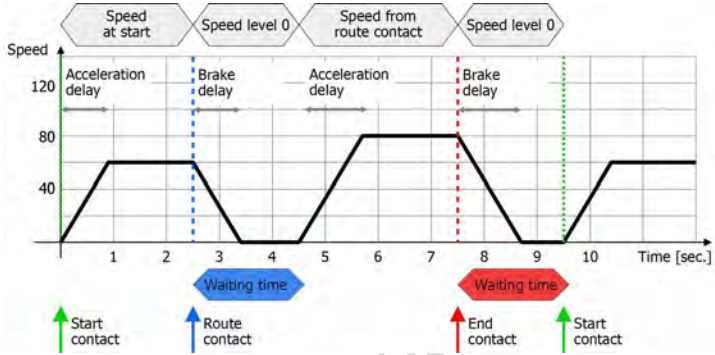

Note: Acceleration and brake delay are parameters of the vehicle decoder.
 A setting for a shuttle section is shown. The start and end contacts are identical contacts on the layout.

Example 4	Start contact	Route contact	Endcontact
Delay:	---	5/10 seconds	10/10 seconds
Waiting time:	---	2 seconds	2 seconds

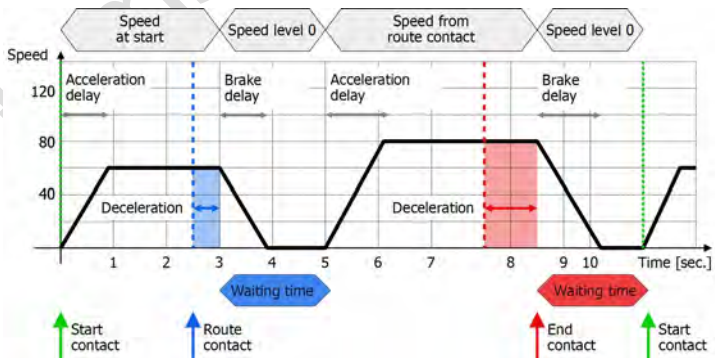

Note: Acceleration and brake delay are parameters of the vehicle decoder.
 A setting for a shuttle section is shown. The start and end contacts are identical contacts on the layout.

tams elektronik

7. Updates

The mc² central unit is a mature product corresponding to the current state of the art and has been intensively tested. However, the large number of connection options for various digital devices and the resulting huge number of possible combinations, as well as the variety of system concepts and possibilities for system implementation, make it impossible to test all conceivable constellations in advance. Despite all tests, we therefore cannot exclude the possibility of problems occurring during operation with your system and your digital devices. We make every effort to correct problems caused by errors in the firmware and/or the web interface of your mc² as quickly as possible.

Future developments in the field of digital control of model railways - both in terms of standardisation and digital devices - will require further developments of the firmware and/or the web interface of your mc². In addition, there will be additional functions that we develop for the mc² central unit.

Free updates for the mc²

You benefit from the further development of the mc² by installing updates for the firmware and/or the mc² Toolbox. Updates are free of charge for you. The latest available and installed versions of the firmware and the web interface are displayed in the "Update" menu item of the mc² Toolbox. You can also check the current version of your mc² in the "System info" menu item.

How to update your mc² is described in the direct help in the menu item "Update".

Updates for other EasyControl devices

Under the menu item "Update" of the mc²-Toolbox, you can also carry out updates for further digital devices for the EasyControl digital system. The prerequisite is that the device is connected to your mc² via the EasyNet interface. How to carry out updates for these devices is described in the direct help in the menu item "Update".

Recovery software

For mostly incomprehensible reasons, an update may fail. If your mc² then no longer responds to renewed attempts to start an update, proceed as follows:

- Download the recovery software (mc2recovery.exe) from the download area of our homepage (www.tams-online.de) to your PC.
- Install the software mc2recovery.exe on your PC and start it.
- Enter the data path under which you have saved the current firmware for the mc².
- Switch off the supply voltage of the mc².
- Keep the "STOP" and "GO" keys pressed while switching the supply voltage back on. A dot flashes alternately in the two segments of the display.
- Keep the "STOP" and "GO" buttons pressed until the update starts. Release the buttons as soon as the display shows the progress of the update (in %).

tams elektronik

8. Checklist for troubleshooting

When delivered, your mc² has the password "Tams". If you have changed the password and then forgotten it, you can display it on the web developer console of your browser. Click on set (password) after opening, the password will then be displayed in the console. On the Internet you can find instructions on how to get to the web developer console of your browser.

8.1. Heat generation

Heating of the central unit and the power supply unit during operation is normal and harmless. Under continuous full load, i.e. when the integrated booster supplies more than 6 A of current (versions 1 and 2-6) or 8.5 A of current (version 2-9) for a longer period of time, the temperature can reach up to 75 °C. If a high temperature is reached at low load, the mc² probably has a defect.

Warning:

If you notice severe overheating on the mc² and/or the power supply unit, disconnect the central unit and the power supply unit from the supply voltage immediately. **Fire hazard!** Send in the mc² and the power supply unit for testing.

8.2. Automatic safety shutdown

The mc² switches off the track voltage and indicates a short circuit.

Indication in the display: "SH" | RGB-LEDs: red and violet alternately

- Possible cause: short circuit on the rails → Eliminate the short circuit.
- Possible cause: exceeding the maximum permissible current in a booster circuit → Check whether the maximum current for the booster(s) is set correctly (menu item "System / Boosters"). → If the maximum current was set correctly, you must reduce the current consumption in the booster circuit.
- Possible cause: exceeding the maximum permissible total current (= 6.67 A or 9.2 A). The reason is usually a permanently high current consumption in the booster circuit of the integrated booster with a simultaneously large number of external digital devices at the CAN, LocoNet, EasyNet and/or BiDiB interface. → Reduce the current consumption. Supply the external digital devices via an external power supply if possible.

The mc² switches off the track voltage and indicates overheating.

Indication in the display: "ot" | RGB-LEDs: yellow

- Possible cause: overheating → Check whether the mc² has sufficient distance to surrounding surfaces and/or is exposed to direct sunlight. Ensure unhindered air exchange.
- Possible cause: Permanently high current consumption just below the maximum permissible total current (= 6.67 A or 9.2 A). The reason is usually a permanently high current consumption in the booster circuit of the integrated booster with a simultaneous large number of external digital devices at the CAN, LocoNet, EasyNet and/or BiDiB interface. → Reduce the current consumption. If possible, supply the external digital devices via an external power supply.

The power supply unit switches off and then on again after a while.

- Possible cause: overload → Reduce the number of connected additional devices and/or the power consumption in the booster circuit of the integrated booster. As soon as the overload is eliminated, the power supply unit is automatically switched on again.
- Possible cause: Overvoltage → As soon as the input voltage of the power supply unit is within the permissible range again, it is automatically switched on again.
- Possible cause: Overheating → Check whether the power supply unit has sufficient distance to surrounding surfaces and/or is exposed to direct sunlight. Ensure an unhindered exchange of air. As soon as the power supply unit has cooled down, it is automatically switched on again.

8.3. Problems with the power supply

The input voltage is less than 22 V.

Indication on the display: "Pf" or "LP" | RGB LEDs: red

Warning:

If the display shows "Pf" (Power Fail) or "LP" (Low Power), disconnect the central unit from the power supply immediately. There are incalculable risks in continuing to operate the system!

- Possible cause: Overload of the power supply unit. The reason is usually a permanently high current consumption in the booster circuit of the integrated booster with a simultaneous large number of external digital devices at the CAN, LoCoNet, EasyNet and/or BiDiB interface. → Reduce the current consumption. If possible, supply the external digital devices via an external power supply.
- Possible cause: defect at the power supply unit. → Check the supply voltage of the mc² in the menu item "System / Info". If it is below 22 V despite low current consumption in the booster circuit of the integrated booster and a low number of connected external digital devices, the power supply unit is probably defective. Send it in for checking.

8.4. Problems with external input devices

The decoders do not respond to digital commands entered at a digital central unit on the Sniffer.

- Possible cause: The central unit on the Sniffer is not set to DCC or Motorola as the format for track output. However, the mc² cannot evaluate digital commands in different formats. → Change the setting at the connected command station.

A locomotive with mfx decoder cannot be controlled with an input device connected to the CAN interface of the mc².

- Possible cause: The mc² cannot control mfx decoders directly. → You must first assign an address for the m3 format to the decoder (menu item "Operation / Programming").

8.5. Problems when programming and controlling vehicles

A locomotive does not react to driving and switching commands, although you have entered the correct locomotive address.

- Possible cause: A wrong data format is assigned to the locomotive address. → Change the data format.

Vehicles with DCC decoder

When programming a DCC decoder the mc² displays an error message.

- Possible cause: You have selected a programming type that is not supported by the decoder. → Check with the instructions for the decoder which programming types it is designed for.

A locomotive with DCC decoder is already running at very high speed at speed level 1.

- Possible cause: The number of speed steps "128" is assigned to the locomotive address, but the locomotive decoder only supports 14 or 28 speed steps. → Change the number of speed steps.

On a locomotive with DCC decoder the light cannot be switched and / or the light flickers when switching up the speed steps.

- Possible cause: The setting of the number of speed steps on the decoder and on the mc² do not match. → Change the number of speed steps on the decoder or on the mc².

Vehicles with Motorola decoder

When switching up the speed steps for a locomotive with Motorola decoder, the speed is actually changed only at every second speed step.

- Possible cause: The number of speed steps "27a" or "27b" is assigned to the locomotive decoder, but the locomotive decoder supports only 14 speed steps. → Change the number of speed steps.

During operation locomotives with Motorola I decoders cause problems: They do not react to driving and switching commands or have a bad driving behaviour.

- Possible cause: The length of the signal pause is set incorrectly. → Change the pause time.

During operation, function models with Motorola decoders do not react correctly to digital commands.

- Possible cause: The length of the signal pause is set incorrectly. → Change the pause time.

Vehicles with mfx decoder

Vehicles with mfx decoder cannot be controlled in Motorola or DCC format, although these formats are entered for them in the locomotive list.

- Possible cause: An m3 address was called up (e.g. by accidentally entering a vehicle decoder address >10,239). → Perform a reset on the mc². Should an m3 address be active on one of the virtual controllers or an EasyControl device, deactivate it before performing the reset. If you generally do not want to control your mfx locomotives in the m3 format, you can deactivate this format in the menu item "System / Protocol".

Tractions

The locomotives of a double traction run in opposite directions.

- Possible cause: When forming the double traction you did not invert the direction of travel for one locomotive. → Form the double traction again.

8.6. Problems when switching points and other accessories

The turnouts or the accessories cannot be switched.

- Possible cause: The data format for the accessory decoder is set incorrectly. → Change the data format.
- Possible cause: Accessory decoders for the Motorola format are connected with the wrong polarity. → Check the connections and change the polarity at the track or decoder connection if necessary.

8.7. Problems with s88 modules

When testing an s88 module all inputs are shown as occupied although they are (partly) free.

- Possible cause: The connection to the 6-pole plug of a feedback module is wrongly polarised. → Check whether the 6-pole socket has been plugged in the right way round. If the connection is made via an s88-N adapter, check whether you have used the correct adapter or connected the adapter the right way round.

You cannot test all s88 modules although they are connected correctly.

- Possible cause: The number of s88 modules is set incorrectly. → Check and change the number of s88 modules. Note: Arithmetically, one s88 feedback has 16 contacts each. Feedback units with 8 contacts therefore only count as ½ feedback unit.

8.8. Problems with the software update

The firmware update for the mc² fails.

- Possible cause: An attempt was made to load an incorrect file. → Check whether you had selected the correct file and start the update again.
- If the firmware update is still not possible after several attempts or can no longer be started, you must load the recovery software and run the programme. → Section 7

During the update of a connected EasyNet device, the progress bar jumps back to the beginning (several times).

- This is not an error. The update programme continuously checks whether the data transfer is correct. If this is not the case, the programme restarts the update for security reasons.

tams elektronik

8.9. Technical hotline

Under the menu item "Contact" in the footer of the mc²-Toolbox you will find all information about our technical hotline and a contact form. The data can also be found on our homepage at www.tams-online.de.

8.10. Repairs

You can send us a defective mc² and/or a defective power supply unit for testing and repair. You will find the address under the menu item "Contact" in the footer of the mc²-Toolbox, on the back of the mc² guide and on the last page of this manual. Please do not send us your return freight collect. In the event of a warranty or guarantee claim, we will reimburse you for the regular shipping costs.

Please enclose the following with your shipment

- proof of purchase as evidence of any warranty or guarantee claim
- a brief description of the defect
- the address to which we should return the product(s)
- your email address and/or a telephone number where we can reach you in case of queries.

Costs

The inspection of returned products is free of charge for you. In the event of a warranty or guarantee claim, the repair and return are also free of charge for you.

If there is no warranty or guarantee case, we will charge you the costs of the repair and the costs of the return. We charge a maximum of 50% of the new price for the repair according to our valid price list.

Carrying out the repair(s)

By sending in the product(s), you give us the order to inspect and repair it. We reserve the right to refuse the repair if it is technically impossible or uneconomical. In the event of a warranty or guarantee claim, you will then receive a replacement free of charge.

Cost estimates

Repairs for which we charge less than € 25.00 per item plus shipping costs will be carried out without further consultation with you. If the repair costs are higher, we will contact you and carry out the repair only after you have confirmed the repair order.

Please do not send us your return freight collect. In the event of a warranty or guarantee claim, we will reimburse you for the regular shipping costs.

9. Technical data

9.1. Digital control unit mc²

Digital protocols

Data formats	Motorola-I and -II DCC (according to NMRA and RCN standard) m3 (to control mfx decoders)
Vehicle decoder addresses	Motorola: 255 (1 – 255) DCC: 10,239 (1 – 10,239) m3: 16,384 (1 – 16,384)
Speed levels	Motorola: 14 or 27 (a or b) DCC: 14, 28 or 128 m3: 126
Functions	Motorola: function, f1 to f4 DCC: f0 to f31 or f32,768 m3: f0, f1 to f31
Accessory decoder addresses	Motorola: 1,020 (1 – 1,020) DCC: 2,040 (1 – 2,040) m3: ---
Feedback formats	RailCom

Interfaces

For the connection of external input devices	Märklin-Can-Bus (10-pole) LocoNet (RJ12) EasyNet (RJ45) XpressNet (RJ12) Sniffer (2-pole, grid dimension 2,54 mm)
For the connection of external feedback modules	Märklin-Can-Bus (10-pole) LocoNet (RJ12) s88-N (RJ4) Number of s88 modules: 52 s88 or s88-compatible modules (832 contacts) BiDiB (RJ45) max. number of BiDiB nodes: 31 in one level
Computer interface	LAN (RJ45) / TCP. Protocols: BiDiB, p50x, Z21
Audio interface	Line-out output for connecting active speakers or amplifiers (2.5 mm stereo jack plug)

Interfaces for external boosters	Märklin-compatible DCC compliant BiDiB LocoNet (versions V2-6 and V2-9 only)
Track outputs	Main track DCC programming track

Electrical properties

Power supply	24 volts direct current <small>Note: Only the power supply unit included in the scope of delivery is permitted as power supply for the mc² including integrated booster!</small>
Maximum total current	Versions V1 and V2-6: 6.67 A Version V2-9: 9.2 A
Maximum current for external digital devices	1,200 mA <small>Note: The specification refers to all digital devices on the CAN, LocoNet, EasyNet, XpressNet and BiDiB interfaces that are supplied with power via the respective bus line.</small>
for s88 modules	maximum 200 mA
for s88 Loconet modules	maximum 500 mA
Current consumption	approx. 150 mA (without consumers)

Integrated Booster

Output voltage	8 to 22 volts digital voltage (regulated) adjustable in 1 V steps
Maximum output current	Versions V1 and V2-6: 1 to 6.5 A Version V2-9: 1 to 9 A adjustable in 0.5 A steps
Power consumption	Versions V1 and V2-6: max. 143 Watt Version V2-9: max. 198 Watt
Digital formats	DCC, Motorola, m3
Feedback format	RailCom (RailCom cutout can be switched off) integrated global RailCom detector
Output signal	symmetrical
Safety	automatic switch-off in case of overload ("short-circuit shutdown") Short-circuit sensitivity: 10 - 2,000 ms (adjustable)

Protection

Protection class	IP 20 Meaning: Protected against solid foreign bodies with a diameter ≥ 12.5 mm and access with a finger. No protection against water.
Overload	100 ~ 110% of the rated output power Protection: Switching off the voltage at the track output
Overtemperature	Switching off the voltage at the track output

Environment

	For use in closed rooms Note: To allow unhindered air exchange and to protect the unit from overheating, a distance of at least 20 cm must be maintained between the side, top and rear surfaces and surrounding surfaces.
Ambient temperature during operation	0 ~ + 60 °C
Permissible relative humidity during operation	10 ~ 85% (non-condensing)
Ambient temperature during storage	- 10 ~ + 80 °C
Permissible relative humidity during storage	10 ~ 85% (non-condensing)

Other features

Dimensions (approx.)	175 x 154 x 82 mm
Weight (approx.)	831 g

9.2. Power supply unit for versions V1 and V2-6 of the mc²

Manufacturer	MEAN WELL ENTERPRISE Co. Ltd.
Type designation	GSM160B24-R7B
Output	
Output voltage	24 VDC
Rated current	6.67 A
Output current	0 – 6.67 A
Rated powerNennleistung	max. 160 watts
Input	
Input voltage	80 ~ 264 VAC or 113 ~ 370 VDC
Frequency range	47 ~ 63Hz
Input current	90A / 115VAC or 110A / 230VAC
Efficiency	average: 93,5 % at low load (10%): 87.5 %
Power consumption at zero load	< 0,15 W
Protection	
Protection type	IP 22 Meaning: Protected against solid foreign bodies with diameter ≥ 12.5 mm and access with a finger. Protection against falling dripping water when the enclosure is tilted up to 15°.
Protection class	 (= Protection class 2)
Overload	105 ~ 150% of the rated output power Protection mode: Hiccup mode, i.e. automatic recovery after elimination of fault condition
Overvoltage	105 ~ 135% of the rated output voltage Protection mode: Switching off the output voltage, switching on again for recovery
Overtemperature	Protection mode: Switching off the output voltage, switching on again for recovery

Environment



For use in closed rooms

Note: To allow unhindered air exchange and to protect the unit from overheating, a distance of at least 20 cm must be maintained between the side surfaces, the top surfaces and the rear surfaces to ambient surfaces.

Ambient temperature during operation	-30 ~ + 70 °C
--------------------------------------	---------------

Permissible relative humidity during operation	20 ~ 90% (non-condensing)
--	---------------------------

Ambient temperature during storage	- 40 ~ + 85 °C
------------------------------------	----------------

Permissible relative humidity during storage	10 ~ 95% (non-condensing)
--	---------------------------

Connections

Unit connection	Power supply connector 4-pole with snap lock, R7B series
-----------------	--

Mains connection	Mains cable socket 2-pole, IEC 320-C8
------------------	---------------------------------------

Miscellaneous

Dimensions (approx.)	175 x 72 x 35 mm
----------------------	------------------

Weight (approx.)	660 g
------------------	-------

Length of connection cable	1,200 mm ± 50 mm
----------------------------	------------------

9.3. Power supply unit for version V2-9 of the mc²

Manufacturer	MEAN WELL ENTERPRISE Co. Ltd.
Type designation	GSM220B24-R7B

Output

Output voltage	24 VDC
Rated current	9.2 A
Output current	0 – 9.2 A
Rated powerNennleistung	max. 221 watts

Input

Input voltage	80 ~ 264 VAC or 113 ~ 370 VDC
Frequency range	47 ~ 63Hz
Input current	90A / 115VAC or 110A / 230VAC
Efficiency	average: 93,5 % at low load (10%): 87.5 %
Power consumption at zero load	< 0,15 W

Protection

	IP 22
Protection type	Meaning: Protected against solid foreign bodies with diameter ≥ 12.5 mm and access with a finger. Protection against falling dripping water when the enclosure is tilted up to 15°.
Protection class	 (= Protection class 2)
Overload	105 ~ 150% of the rated output power Protection mode: Hiccup mode, i.e. automatic recovery after elimination of fault condition
Overvoltage	105 ~ 135% of the rated output voltage Protection mode: Switching off the output voltage, switching on again for recovery
Overtemperature	Protection mode: Switching off the output voltage, switching on again for recovery

Environment



For use in closed rooms

Note: To allow unhindered air exchange and to protect the unit from overheating, a distance of at least 20 cm must be maintained between the side surfaces, the top surfaces and the rear surfaces to ambient surfaces.

Ambient temperature during operation	-30 ~ + 70 °C
--------------------------------------	---------------

Permissible relative humidity during operation	20 ~ 90% (non-condensing)
--	---------------------------

Ambient temperature during storage	- 40 ~ + 85 °C
------------------------------------	----------------

Permissible relative humidity during storage	10 ~ 95% (non-condensing)
--	---------------------------

Connections

Unit connection	Power supply connector 4-pole with snap lock, R7B series
-----------------	--

Mains connection	Mains cable socket 2-pole, IEC 320-C8
------------------	---------------------------------------

Miscellaneous

Dimensions (approx.)	210 x 85 x 46 mm
----------------------	------------------

Weight (approx.)	1,100 g
------------------	---------

Length of connection cable	1,000 mm ± 50 mm
----------------------------	------------------

tams elektronik

10. Warranty, EC Conformity & WEEE

10.1. Warranty Statement

We voluntarily grant a 2-year warranty for this product from the date of purchase by the original customer, but for a maximum of 3 years after the end of series production of the product. The first customer is the consumer who first purchased the product from us, a dealer or another natural or legal person who resells or installs the product in the course of his or her independent professional activity. The warranty exists in addition to the statutory warranty claims to which the consumer is entitled against the seller.

The scope of the guarantee includes the free repair of defects which can be proven to be due to material processed by us which is not in perfect condition or to manufacturing defects. In the case of kits, we guarantee the completeness and perfect condition of the components, as well as a function of the components in accordance with the characteristic values in uninstalled condition. We guarantee compliance with the technical data if the kit is assembled in accordance with the instructions and the finished circuit is installed and commissioned and operated in the prescribed manner.

We reserve the right to repair, rectify, replace or refund the purchase price. Further claims are excluded. Claims for compensation for consequential damage or from product liability exist only in accordance with the statutory provisions.

A prerequisite for the effectiveness of this guarantee is compliance with the operating instructions. Furthermore, the warranty claim expires in the following cases:

- in the event of unauthorised modification of the circuit,
- in the event of attempted repairs to the finished component or finished unit,
- in the event of damage caused by the intervention of third parties,
- incorrect operation or damage due to negligent handling or misuse.

10.2. EC Declaration of Conformity



This product fulfils the requirements of the following EU directives and therefore bears the CE marking.

2001/95/EU Product Safety Directive

2015/863/EU on the restriction of the use of certain hazardous substances in electrical and electronic equipment (RoHS)

2014/30/EU on electromagnetic compatibility (EMC Directive). Underlying standards:

DIN-EN 55014-1 and 55014-2: Electromagnetic compatibility - Requirements for household appliances, electric tools and similar electrical appliances. Part 1: Emitted interference, Part 2: Immunity to interference

To maintain electromagnetic compatibility during operation, observe the following measures:

Only connect the power supply unit to a professionally installed and fused socket.

Do not make any changes to the original components and follow the instructions in this manual exactly.

Only use original spare parts for repair work.

10.3. Declarations on the WEEE Directive

This product is subject to the requirements of the EU Directive 2012/19/EC on Waste Electrical and Electronic Equipment (WEEE), i.e. the manufacturer, distributor or seller of the product must contribute to the proper disposal and treatment of waste equipment in accordance with EU and national law. This obligation includes

- registration with the registering authorities ("registers") in the country where WEEE is distributed or sold
- the regular reporting of the amount of EEE sold
- the organisation or financing of collection, treatment, recycling and recovery of the products
- for distributors, the establishment of a take-back service where customers can return WEEE free of charge
- for producers, compliance with the Restriction of the Use of Certain Hazardous Substances in Electrical and Electronic Equipment (RoHS) Directive.



The "crossed-out wheeled bin" symbol means that you are legally obliged to recycle the marked equipment at the end of its life. The appliances must not be disposed of with (unsorted) household waste or packaging waste. Dispose of the appliances at special collection and return points, e.g. at recycling centres or at dealers who offer a corresponding take-back service.

Appendix A : Organisations, Manufacturers, Products

The mc² has interfaces for connecting digital devices from various manufacturers, based on data transfer protocols from different manufacturers and organisations. In the list you will find the contact details as well as a selection of products that you can use together with your mc².

Manufacturer Organisation	Address	Internet	Protocols Products (selection)
Working group BiDiB	Wolfgang Kufer, Lodronstr. 9 84453 Mühldorf Germany	http://www.bidib.org	BiDiB-spezifikation
Digitrax, Inc	2443 Transmitter Rd Panama City, FL 32404-3157 USA	www.digitrax.com	LocoNet
Gebr. Märklin & Cie. GmbH	Stuttgarter Str. 55-57 73033 Göppingen Germany	www.maerklin.de	Märklin CAN-Bus Mobile Station (2/3) Central Station (2/3)
Lenz Elektronik GmbH	Vogelsang 14 35398 Gießen Germany	www.lenz-elektronik.de	XpressNet Handheld controllers LH100 and LH101
Lokstoredigital	Stäffelsbergstr. 13 76889 Dörrenbach Deutschland	www.lokstoredigital.de	LoDi-Con B
PIKO Spielwaren GmbH	Lutherstraße 30 96515 Sonneberg Germany	www.piko.de	SmartControl light
RailCommunity	Verband der Hersteller Digitaler Modellbahn- Produkte e.V.	www.railcommunity.de	RailCommunity- Standards (RCN)
Roco Modelleisenbahn GmbH	Plainbachstraße 4 5101 Bergheim Austria	www.roco.cc	Lokmaus Multimaus
Tams Elektronik GmbH	Fuhrberger Str. 4 30625 Hannover Germany	www.tams-online.de	EasyNet HandControl LokControl MasterControl mControl Booster B-4 and B-6 BiDi-Power Power-Splitter s88-Power

Manufacturer Organisation	Address	Internet	Protocols Products (selection)
Uhlenbrock Elektronik GmbH	Mercatorstrasse 6 46244 Bottrop Germany	www.uhlenbrock.de	Handheld controllers FRED and Daisy 2 Intellibox

tams elektronik

Appendix B : Changes and additions

Manual Version 1.10 © 03/2024 for mc²-Toolbox from Version 1.9.0

For version 1.10, we have extensively revised and expanded the previous version 1.03. To keep your manual up to date, we recommend replacing a larger number of pages and adding various additional pages. The page numbers given for the replacement pages refer to the updated version 1.10 of the manual.

Changes / additions	Replacement pages
Title page and contents: complete revision. We recommend replacing all pages.	0.1 – 0.6
Title page: new versions of mc ²	0.1
New version numbers New: Information on versions of mc ²	0.2
New: Table of contents	0.3 – 0.6
1. Getting started	1.1
Package contents: new: "Important notes" sheet	1.1
2. Commissioning	2.1-2.2, 2.4
New: Notes on handling patch cables Additional information on reading the IP address Updated illustration of the toolbox start page	2.1-2.2 2.4
3. "Your mc²": complete revision. We recommend replacing all pages.	3.1 – 3.10
New: Signal box → Section 3. Your mc ²	3.1
New: Support of the DCC-A protocol → Section 3.2. Protocols	3.4
New: LNet interface version 2 of the mc ² → Section 3.2. Protocols	3.4
New: Virtual control unit LocoControl.vi → Section 3.3. Virtual control units	3.6

Changes / additions	Replacement pages
New: Use of wireless control units for the Z21 protocol → Section 3.4. External digital input devices	3.7
New: V2-9 of the mc ² with integrated 9A booster → Section 3.5. Booster	3.8
Additions to the use of external boosters → Section 3.5. Booster	3.8
New: LocoNet-B(ooster) interface from version 2 of the mc ² → Section 3.5. Booster	3.9
New: Support of the Z21 protocol → Section 3.6. Protocols	3.10
4. Connections: complete revision. We recommend replacing all pages.	4.1-4.22
Revision of the warnings for bus cables → Section 4. Connections	4.1 – 4.2
New: LocoNet-B(ooster) interface from version 2 of the mc ² → Section 4.2.2. Devices for the LocoNet	4.5 – 4.6
New: Use of wireless control devices for the Z21 protocol → Section 4.2.6. Devices for the Z21 protocol	4.10
Addition: Power consumption in the s88 → Section 4.4. Connection of s88 feedback devices → Section 4.4.1. Power supply of the devices on the s88 bus	4.12 – 4.13
Supplements for the use of external boosters → Section 4.5. Connection of external boosters	4.14 – 4.20
5. Configuring the system: various changes and additions, changing the page break. We recommend replacing all pages.	5.1-5.7
New: Status can be set when switching on → Section 5.1. System info	5.1
Function icons: Use of custom icons no longer possible → Section 5.2. Vehicles	5.3

Changes / additions	Replacement pages
<p>New: Address assignment for accessory decoders according to standard or deviating from the standard</p> <p>New: Assignment of addresses for BiDiB accessory decoders → Section 5.3. Accessories</p>	5.5
<p>New: Inrush time can be set for the integrated booster</p> <p>New: Switch-off behaviour of the control unit when connecting BiDiB boosters → Section 5.5. Booster</p>	5.7
<p>6. Operation with the mc²: various changes and additions, minor corrections</p>	6.4, 6.7 – 6.10 6.13 – 6.20
<p>New: "Signal box" → Section 6.2. Operation submenu → Section 6.2.7. Signal box → Section 6.15. Signal box</p>	6.4 6.8 6.15 – 6.20
<p>New: Address ranges for BiDiB feedback devices → Section 6.2.1. Feedback devices</p>	6.4
<p>New: Display of LocoNet sensors implemented → Section 6.2.1. Feedback devices</p>	6.4
<p>New: Display of BiDiB messages implemented → Section 6.2.3. Messages</p>	6.7
<p>New: LocoControl.vi → Section 6.2.5. Controls → Section 6.3. Virtual control units → Section 6.3.1. HandControl.vi → Section 6.3.5. LocoControl.vi</p>	6.8 6.9 6.10 6.14
<p>Correction of error in description of SwitchControl.vi → Section 6.3.4. SwitchControl.vi</p>	6.13
<p>7. Update</p>	7.1 – 7-2
<p>Additional information on the currently available and installed software version in the "Update" and "System info" menu items of the toolbox → Section 7. Updates</p>	7.1

Changes / additions	Replacement pages
8. Checklist for troubleshooting	8.5 – 8.6
Additional information on carrying out repairs → Section 8.10. Repairs	8.5 – 8.6
9. Technical data: Additions	9.1 – 9.2 9.6 – 9.7
New: Z21 protocol → Section 9.1. mc ² digital control centre	9.1
New: Versions V2-6 and V2-9 of the mc ² → Section 9.1. mc ² digital control centre	9.2
Addition: maximum current for s88 modules and LocoNet modules → Section 9.1. mc ² digital control centre	9.2
New: Technical data 9.2 A power supply unit → Section 9.3. power supply unit for version V2-9	9.6 – 9.7
10. Warranty, EU conformity & WEEE: no changes	---

Manual Version 1.03 © 06/2022 for mc²-Toolbox from Version 1.6.0

The list gives you an overview of changes or additions and new or changed pages of the manual.

Changes / additions	Replacement pages
New version numbers	0.2
New: Dim light → Toolbox Home → Screenshot of the "Home" page of the Toolbox	2.4
Correction error regarding LNet interface → Section 3.4 External digital input devices	3.6
Change: Colour of RGB LEDs in case of overtemperature Addition: Setting options for the RGB LEDs → Section 6.1.2. Display and RGB LEDs	6.2 and 6.3
New: Automatic registration of DCC-A decoders and direct taking over of a newly registered vehicle in the HandControl.vi user interface → Section 6.3.1. HandControl.vi	6.10
Addition to technical data → Section 9.2. Power supply unit	9.4
New version due to changed legal regulations → Section 10.3. Declarations on the WEEE Directive	10.2

Manual Version 1.02 © 09/2021 for mc²-Toolbox from Version 1.4.0

The list gives you an overview of changes or additions and new or changed pages of the manual.

Changes / Additions	Replacement pages
new version numbers	0.2
Change of page numbers in section 4 → Contents	0.3
Note on page numbers 4.1 to 4.12 (section 4): In version 1.0.2 of the manual, page 4.1 was added after page 4.2. This shifts all page numbers from 4.2 onwards by one number each (example page 4.2 of version 1.0.1 of the manual is page 4.3 of version 1.0.2 of the manual). The following page numbers of the replacement pages refer to the updated version 1.0.2 of the manual).	
Addition to package contents: one RJ 45 dummy plug for BiDiB connection → Section 1. Getting started	1.1
Addition: For connections to the RJ 12 or RJ 45 sockets of the mc ² , standard 1:1 cables must be used in which the wires are connected through 1:1. Using crossover cables can cause irreparable damage to the mc ² . → Section 4. Connections	4.1 and 4.2
Addition: Notes to dummy plug on BiDiB interface and warnings → Section 4.3. Connecting BiDiB devices → Section 4.4. Connecting s88 feedback modules	4.9 and 4.10
Change: LNet interface of the mc ² is not suitable for the connection of LocoNet boosters.. → Section 3.5. Boosters → Section 4.2.2. Devices for the LocoNet → Section 4.5. Connection of external boosters → Section 5.5. Boosters → Section 9.1. Technical Data / Central Unit mc ²	3.7 and 3.8 4.5 4.11 5.6 9.2
Change: The control of LocoNet accessory decoders and the forwarding of (simple) feedback modules for LocoNet are supported from firmware version 1.4. Addition: The system and LocoNet feedback modules or mc ² must be galvanically isolated from each other, either by using galvanically isolated feedback modules or other measures. → Section 4.2.2. Devices for the LocoNet → Section 6.2.1. Feedback	4.5 6.4

Manual Version 1.01 © 05/2021 for mc²-Toolbox from Version 1.1.0

The list gives you an overview of changes or additions and new or changed pages of the manual.

Changes / Additions	Replacement pages
Manual: Editorial changes mc ² Toolbox: Elimination of problems with setting the default format for vehicles with some browsers. Addition of the languages English, French and Dutch	---

tams elektronik

tams elektronik

tams elektronik

tams elektronik

tams elektronik

Further Information and Tips:
<http://www.tams-online.de>

Warranty and Service:
tams elektronik GmbH

Fuhrberger Str. 4
30625 Hannover / GERMANY

Phone: +49 (0)511 / 55 60 60

Fax: +49 (0)511 / 55 61 61

Email: support@tams-online.de

