

Acumulador 1 Serpetín 300L Vitrificado BW300

Nº	Descripción	Cantidad
11	Tableta Ø=35/45 15/10	1
10	Tuerca M6x30	1
9	Tubo 1" x 220 mm 30/10 25°	1
8	Serpentín inferior 1.2m ² . Att. 1"	1
7	Semiabado extremo superior	1
6	Semiabado extremo inferior	1
5	Hoja 1561x1250x25/10 mm	1
4	Boca Ø180/120 mm	1
3	Manguito 1" 1/2" x 50 mm	1
2	Manguito 1/2" x 50 mm	3
1	Manguito 1" x 50 mm	2

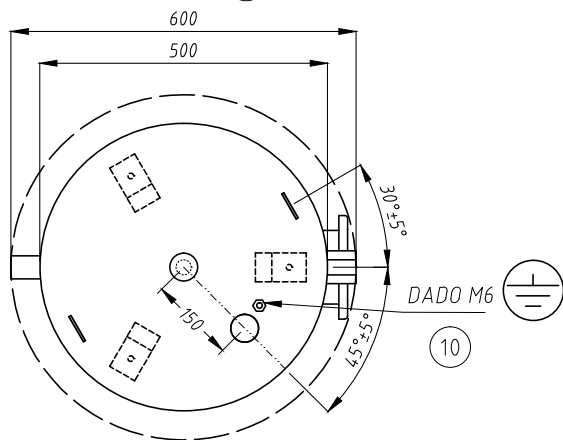

FERCOSOL
Sistemas solares térmicos

Capacidad efectiva (L):	Presión ejercicio 1º(bar):	Peso (Kg):
291	10	89