

Acumulador 1 Serpetín 1000L Vitrificado BASICBWDN1000

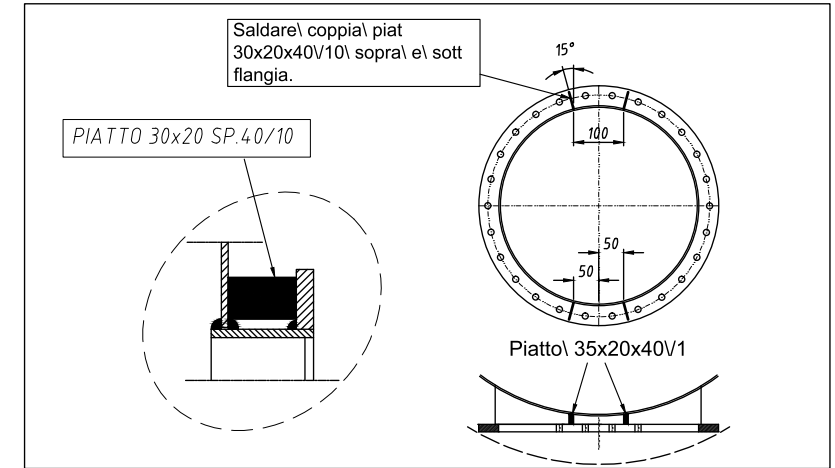

| Nº | Descripción | Cantidad |
|----|--------------------------------------|----------|
| 15 | Tornillo negro TE M6x100mm | 1 |
| 14 | Anillo de refuerzo Ø620/Ø440 | 1 |
| 13 | Tuerca M6x30 | 1 |
| 12 | Tubo 1" x 300 25° | 1 |
| 11 | Serpentín inferior 3.5m ² | 1 |
| 10 | Semielaborado superior | 1 |
| 9 | Semielaborado ingerior | 1 |
| 8 | Hoja 2472 x 1500 x 30/10 | 1 |
| 7 | Boca Ø480/400mm | 1 |
| 6 | Manguito 1 ¼" x 95mm | 2 |
| 5 | Manguito 1 ½" x 150mm | 1 |
| 4 | Manguito 1 ½" x 105mm | 1 |
| 3 | Manguito 1" x 105 mm | 1 |
| 2 | Manguito 1 ½" x 105mm | 3 |
| 1 | Conexión 1 ¼" x 125mm | 1 |

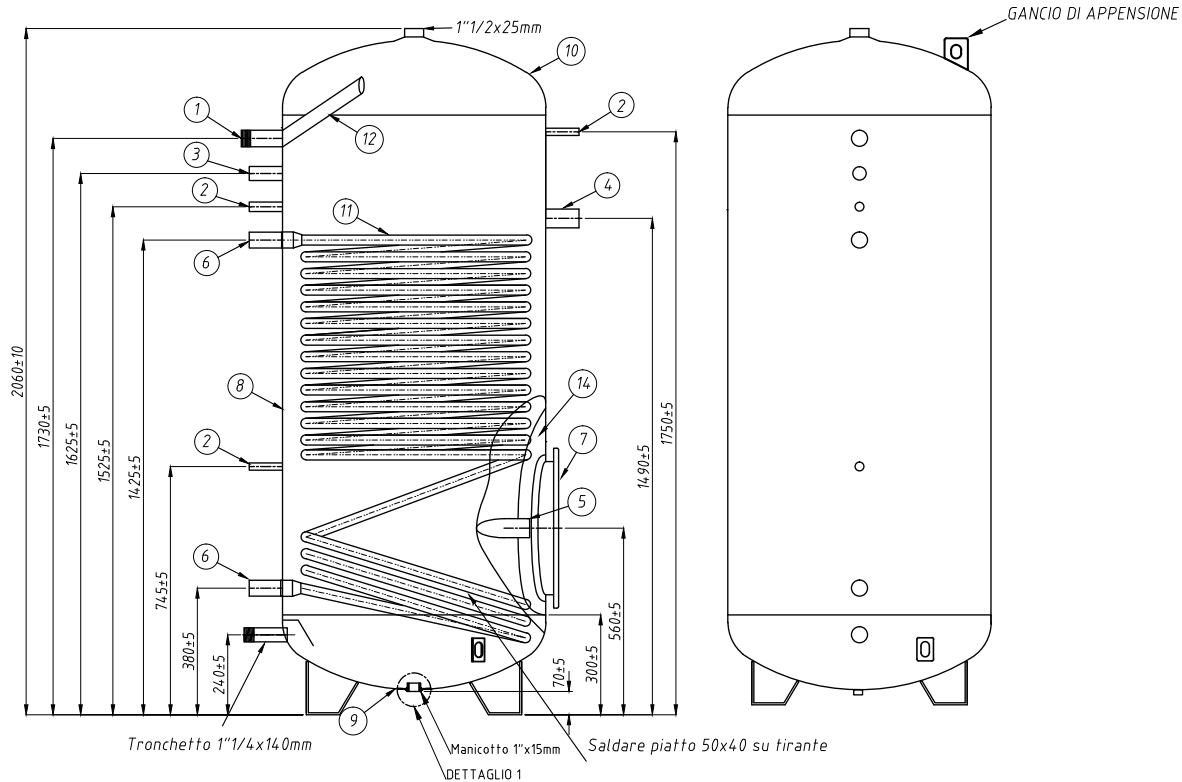
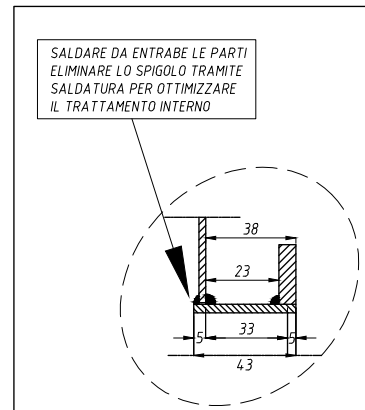
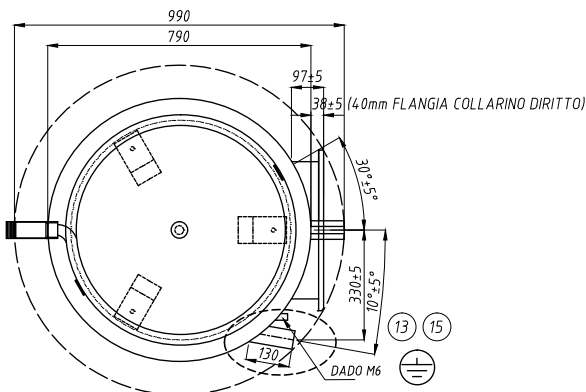

DETAGLIO 1
SCALA 2:1

SALDARE ALL'INTERNO
E ALL'ESTERNO

| Capacidad efectiva (L): | Presión ejercicio 1º(bar): | Peso (Kg): |
|-------------------------|----------------------------|------------|
| 932 | 10 | - |