

## Acumulador 1 Serpetín 2.000L WWDN2000/N

Nº	Descripción	Cantidad
13	Aireador Ø35/45 15/10	1
12	Tuerca M6x30	1
11	Tubo 1" ¼ x 420mm 20°	1
10	Serpentín inferior 4.3 mq. Conex. 1" ¼	1
9	Semi acabado extremo superior	1
8	Semi acabado extremo inferior	1
7	Hoja 3444x1800x30/10	1
6	Boca Ø480/400 x Ø1000 al Ø1250	1
5	Manguito 1" ¼ x 95 mm	2
4	Manguito 1" ½ x 100 mm	2
3	Manguito 1" x 100 mm	1
2	Manguito ½" x 100 mm	3
1	Manguito 1" ½ x 130 mm	1

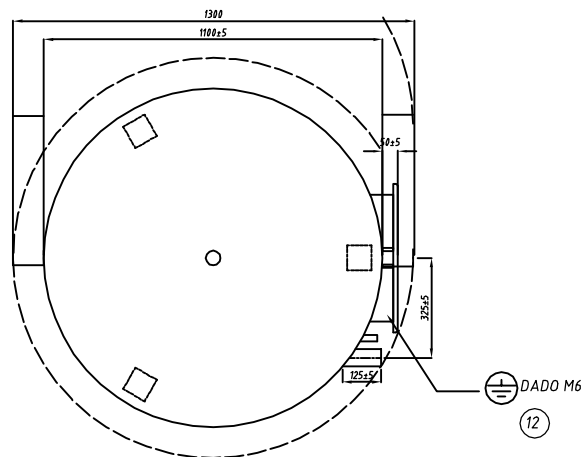

**FERCOSOL**  
*Sistemas solares térmicos*

Capacidad efectiva (L):	Presión ejercicio 1º(bar):	Peso (Kg):
2.054	6	410