



INSTALLATION INSTRUCTIONS

Accessory
QUICK SHIFTER
P/N 08U71-MKS-E00

Application
CRF1100A/A2/A4

Publication No.
MII
Issue Date
September 2019

Honda Dealer: Please give a copy of these instructions to your customer.

PARTS LIST

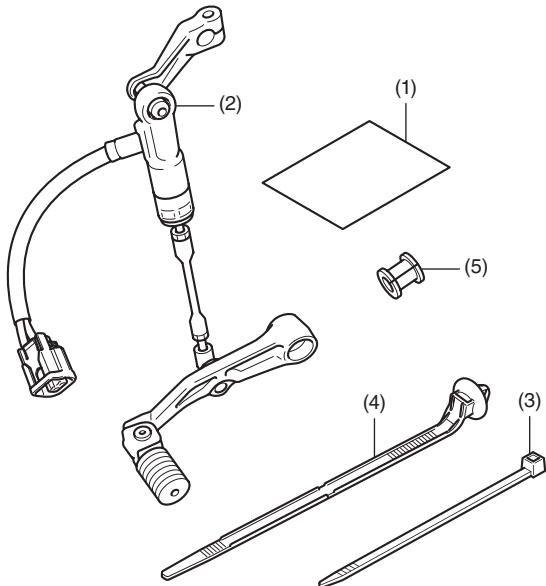

No.	Description	Qty
(1)	URL paper	1
(2)	Gear change pedal	1
(3)	Wire tie	2
(4)	Clip band	1
(5)	Protector	1

SUPPLIES REQUIRED

- Nippers
- Grease
- Electrical tape
- Scale
- Scissors
- Marker

TORQUE CHART

Refer to the Service Manual for the torque values of the removed parts.

INSTALLATION

▲ CAUTION

- To prevent burns, allow the engine, exhaust system, radiator, etc., to cool before installing the accessory.

NOTE:

- Do not disassemble the gear change pedal.
- Disconnect the negative (-) cable from the battery before installing this accessory.
- The memories of the clock will be erased when you disconnect the battery. Reset the memories after reconnecting the battery.
- Cut the wire tie and clip band at 5 mm from the lock part after attaching them to the wire harnesses. Do not allow the cut part of the wire tie and clip band to interfere with another harness or brake hose.
- Reinstall the removed parts on the motorcycle and make sure that the wires and harnesses are not pinched.
- Initialization is necessary after installing this accessory.

1. Remove the tool box and disconnect the negative (-) cable of the battery.

<Left side>

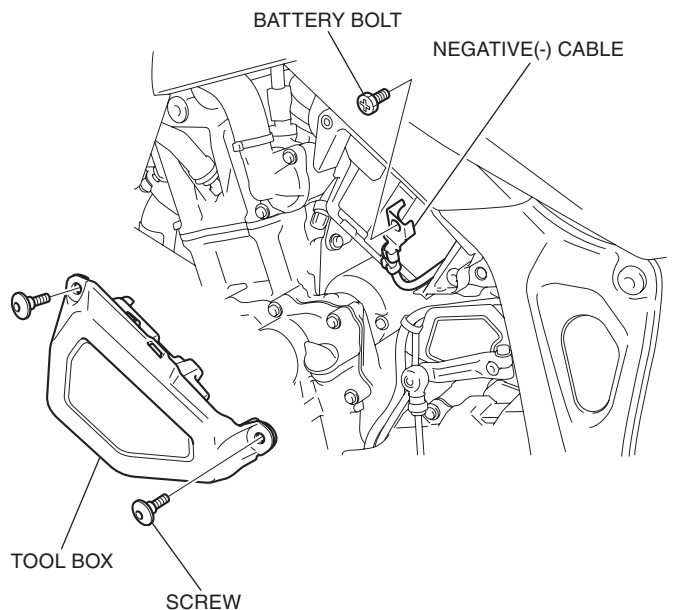

2. Remove the bolts as shown.

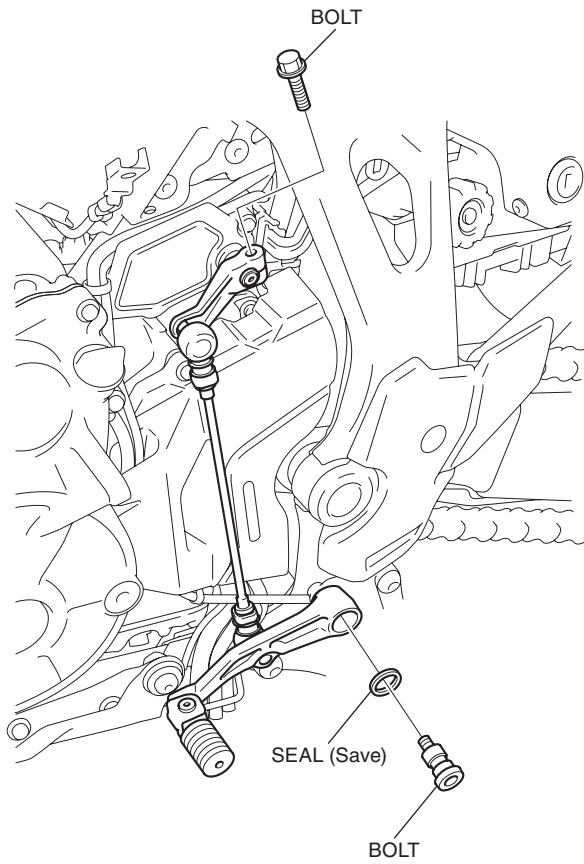

3. Remove the change pedal as shown.

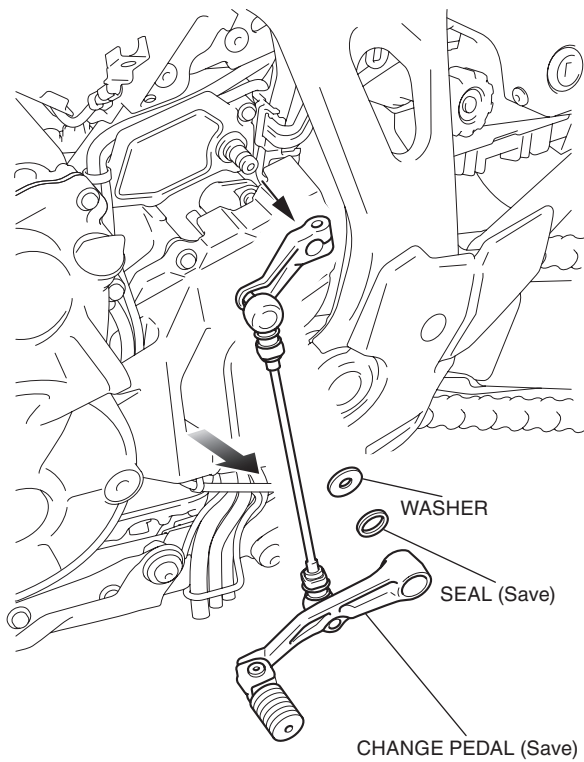

4. Remove the dummy connector as shown.

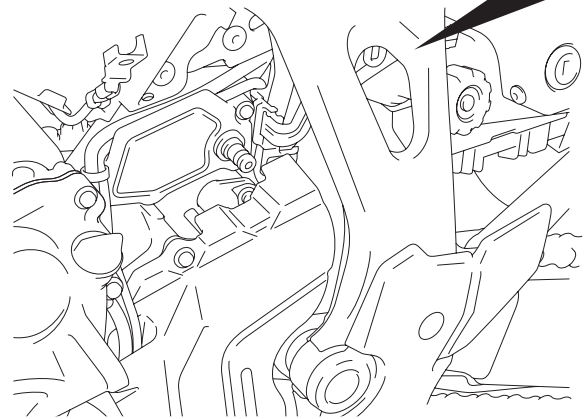
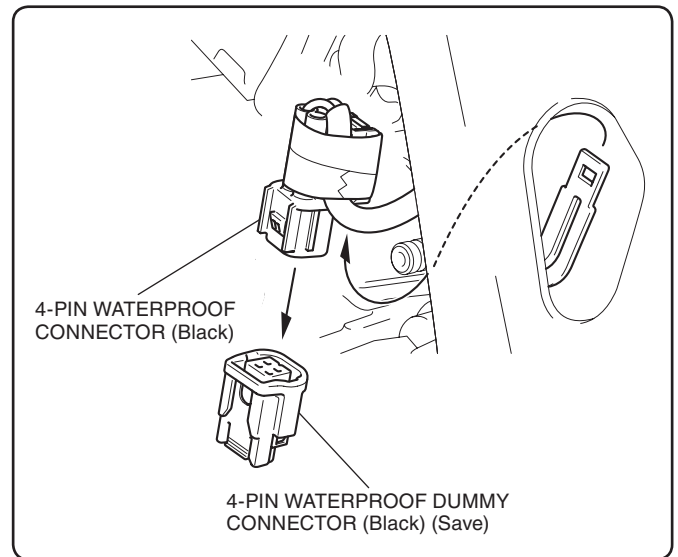

5. Mark the gear change pedal harness at the position of the dimensions shown.

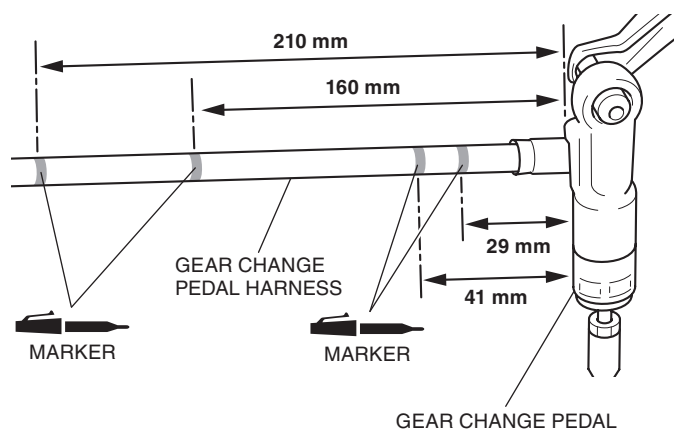

6. Cut the tape as shown location to the indicated dimension.

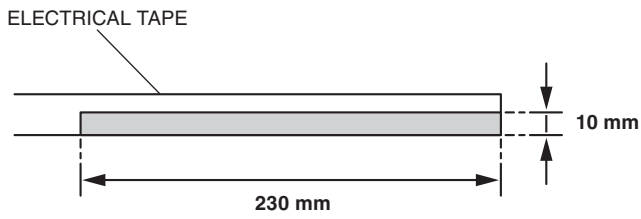

7. Wind the electrical tape as shown.

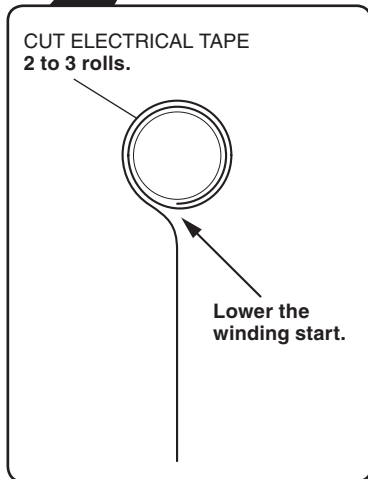
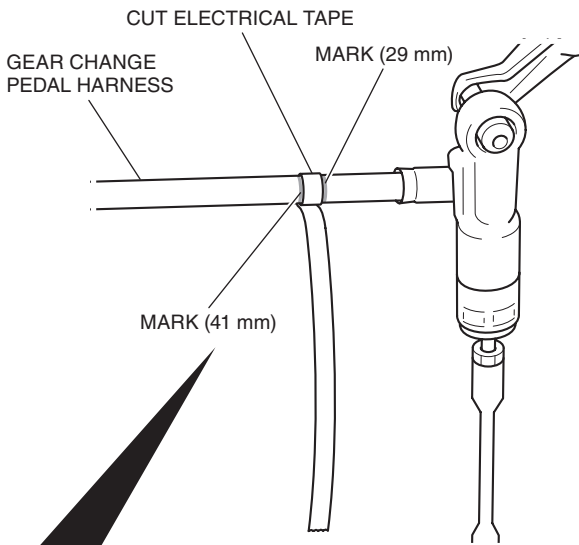

8. Install the protector as shown.

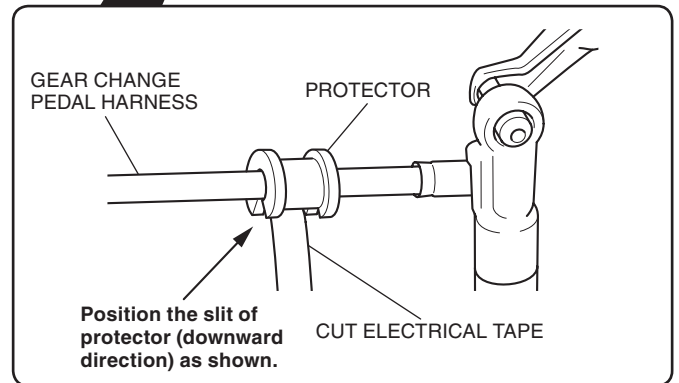
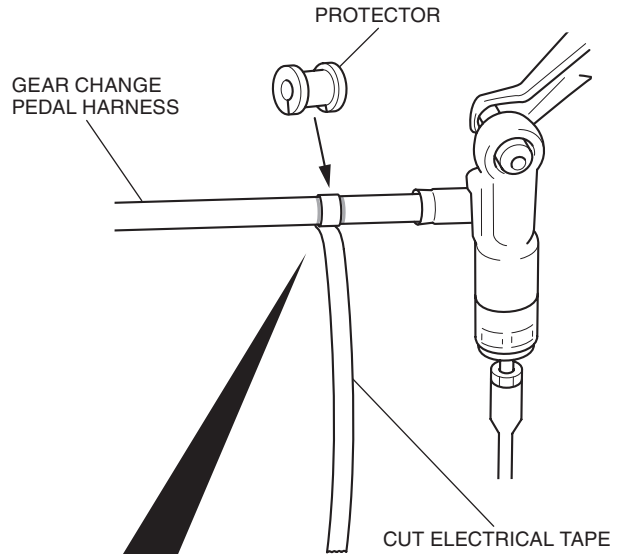

9. Secure the protector with electrical tape as shown.
- Confirm that the secured protector is not off to side.

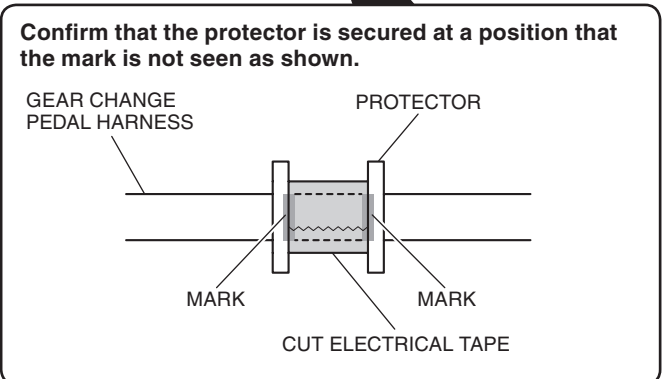
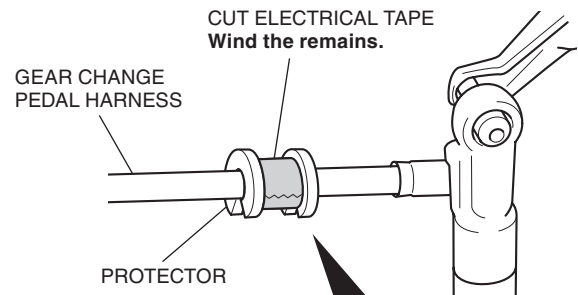

10. Secure the gear change pedal harness with the wire tie as shown.

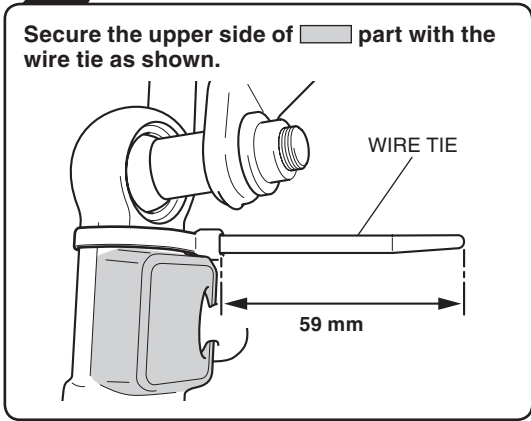
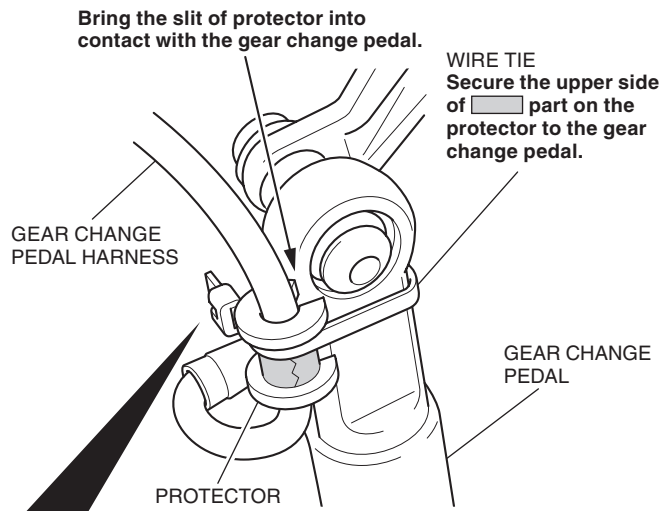

11. Secure the gear change pedal harness in the position of the dimension shown.

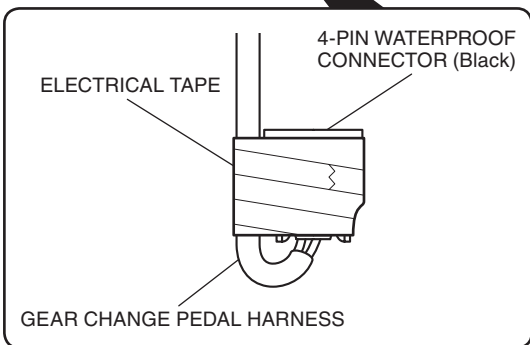
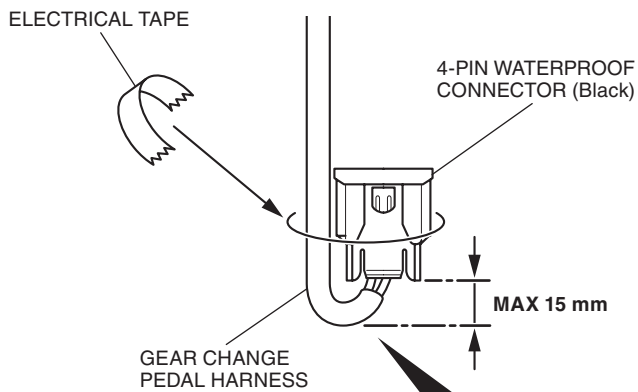

12. Install the gear change pedal as shown.

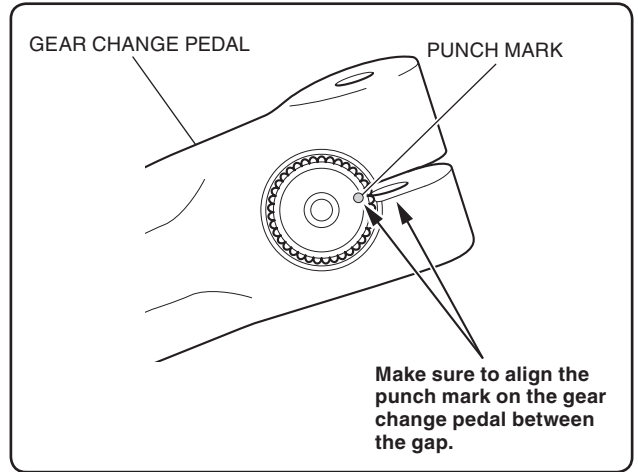

13. Apply grease to the positions shown.

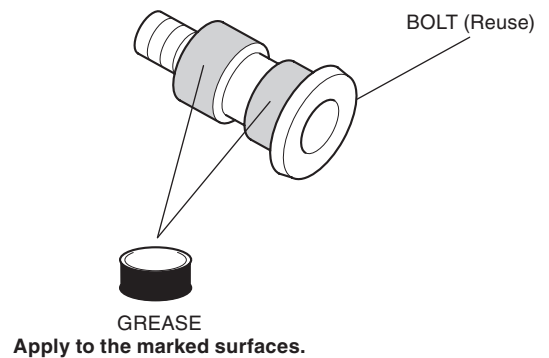

14. Filling grease to the position shown.

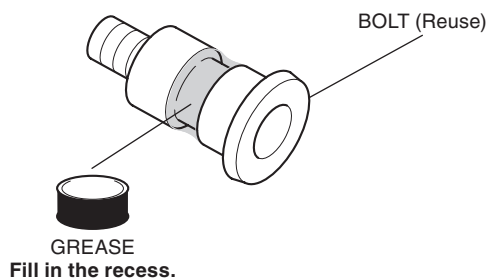

15. Install the bolts as shown.

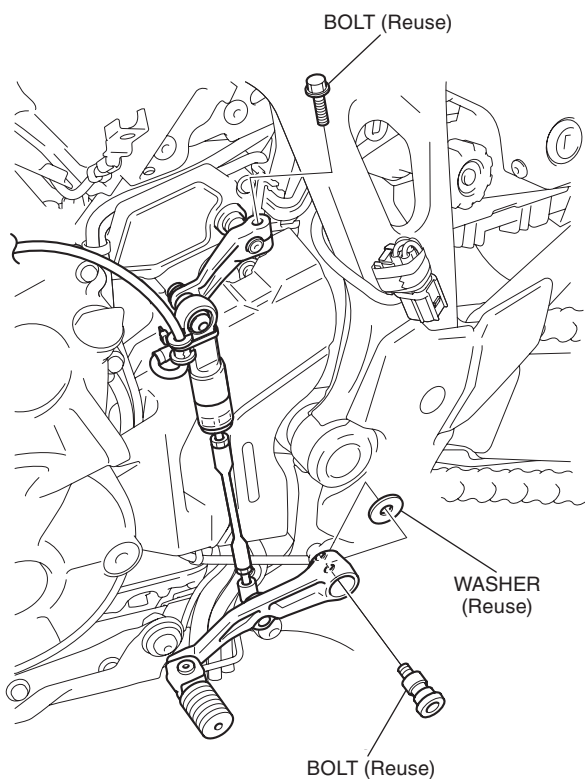

16. Connect the gear change pedal harness as shown.

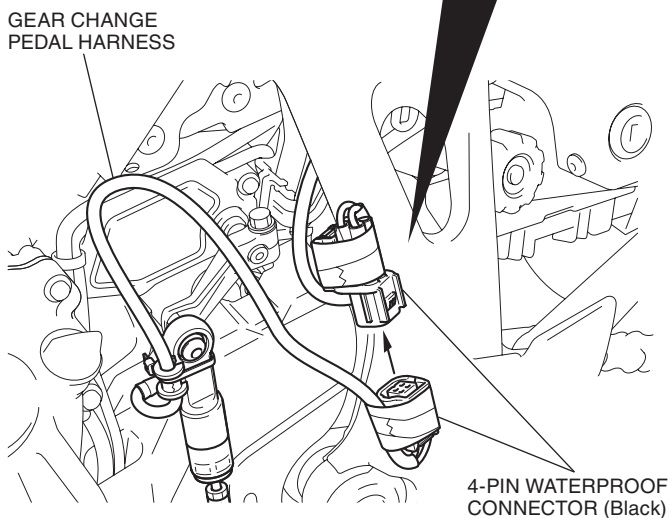
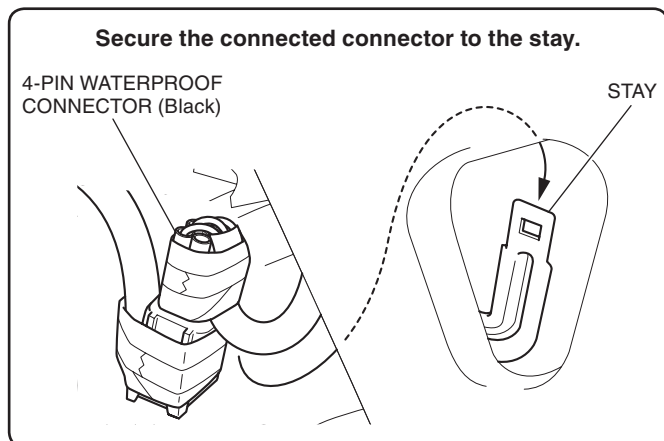

17. Install the clip band as shown.

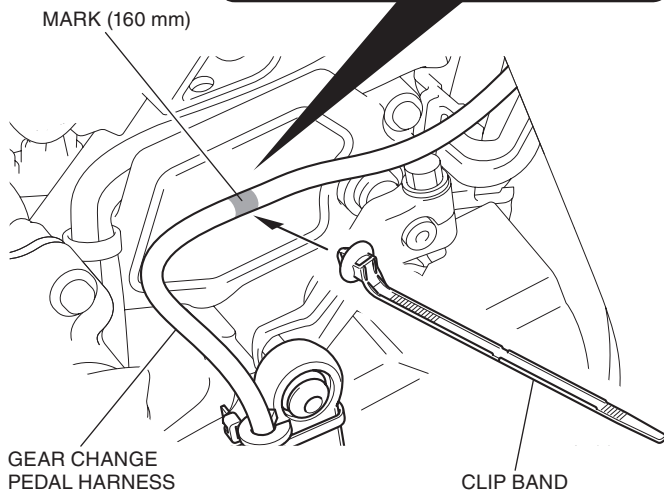
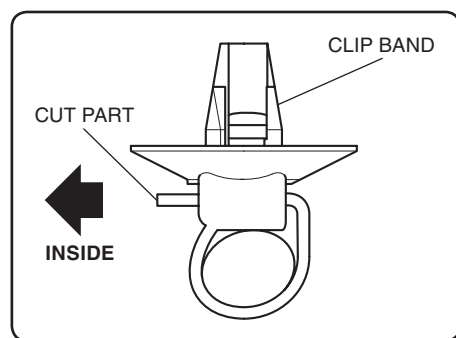

18. Secure the clip band as shown.

- **Bring the cut part of the clip band to the inside.**

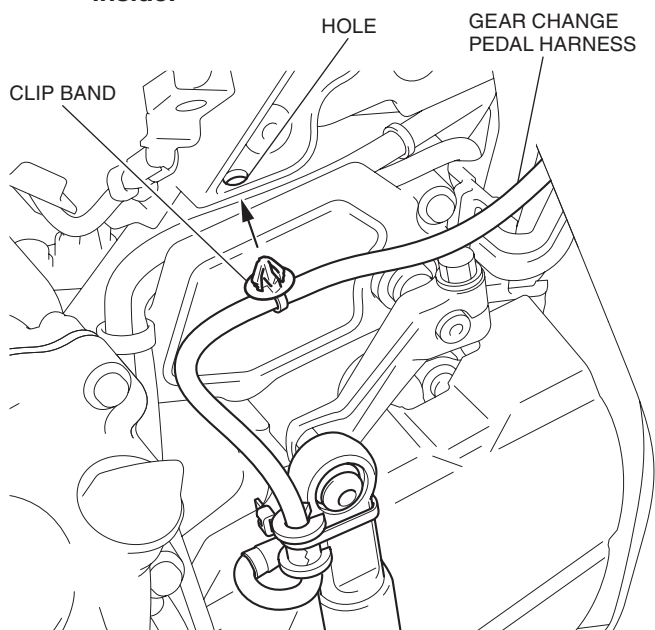

19. Secure the gear change switch harness with the wire tie as shown.

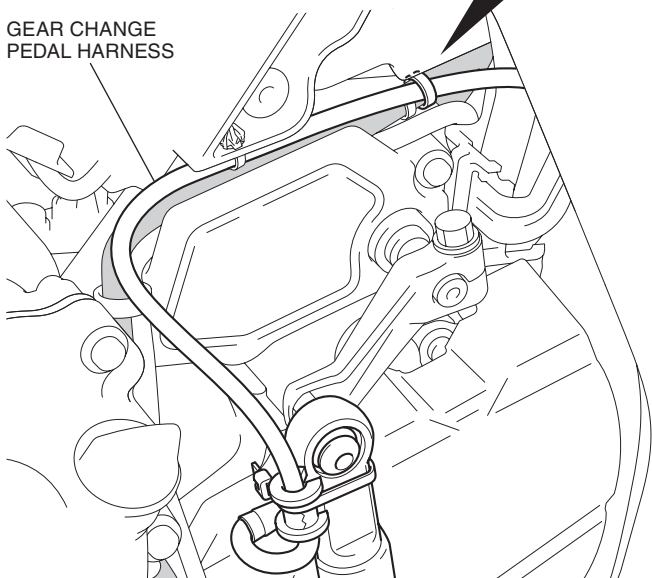
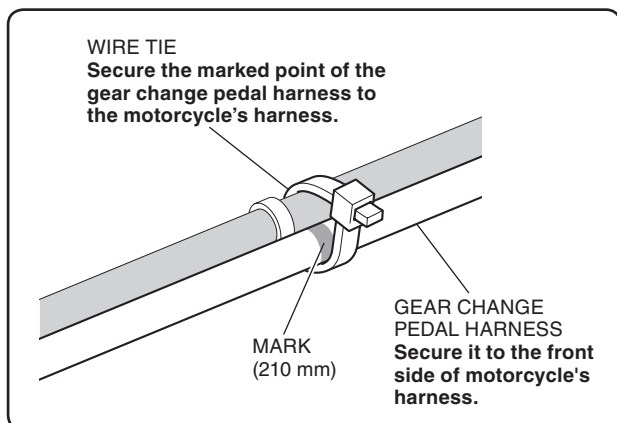

20. Install the motorcycle's parts in the reverse order of removal.

- **Confirm that any wire harness is not caught or too tight.**
- **After installing the quick shifter, perform the initialization.**

21. Check the quick shifter, headlight and the other lights for proper operation.
22. Confirm that there is no trapping or cramping of the harness while shifting gears.
23. Confirm that there is no interference of the harness while shifting down.

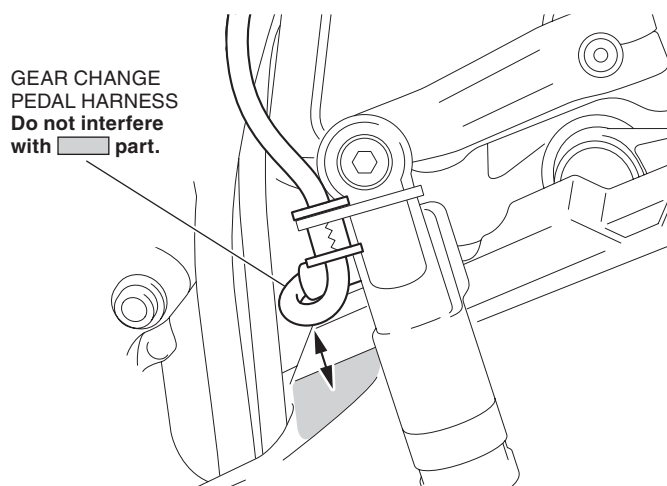

INITIALIZATION INSTRUCTIONS

1. Connect the SCS short connector (070MZ-0010300) to the DLC.
2. Turn the ignition switch ON and engine stop switch “”:
 - **Do not start the engine.**
3. Pull backward and hold the PAGE switch or touch the clock area of the multi-information display.

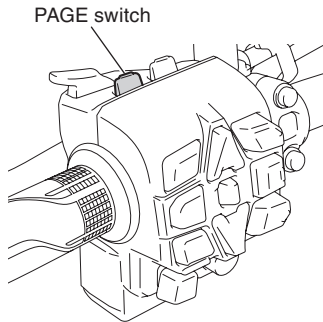

4. Select the “Settings”, and then press the ENT switch.

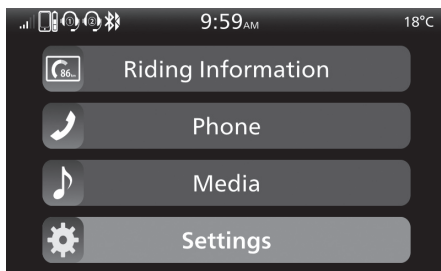

5. Select the “Service”, and then press the ENT switch.

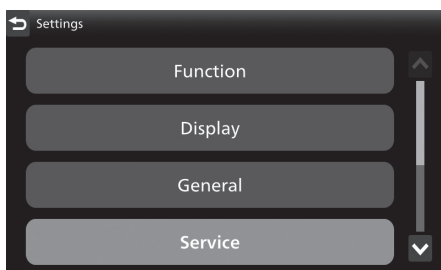

6. Select the “Equipment”, and then press the ENT switch.

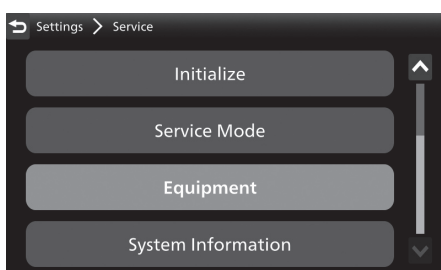

7. Select the “Quickshifter”, and then press the ENT switch to “ON” the function.

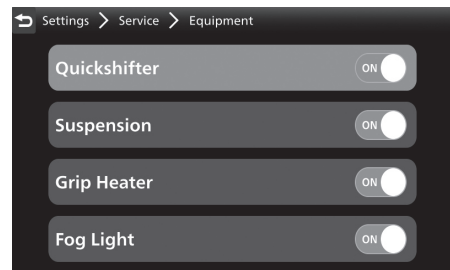

8. Return to the “Settings”.
9. Select the “Function”, and then press the ENT switch.

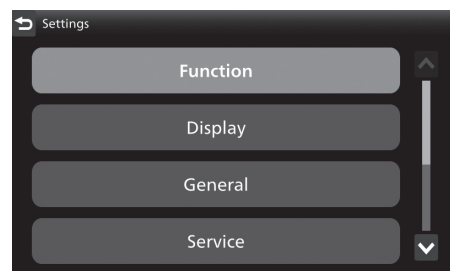

10. Select the “Quickshifter”, and then press the ENT switch.

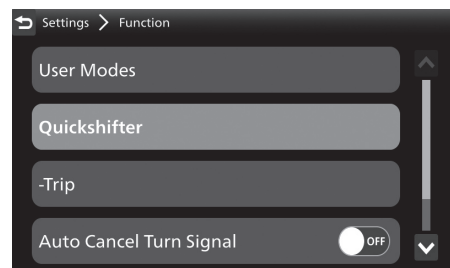

11. Select the “Up” and “Down” to set respectively in the position other than “Off”.

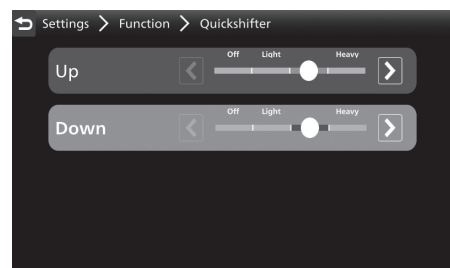

12. Return to the “Settings”.
13. Select the “Initialize”, and then press the ENT switch.

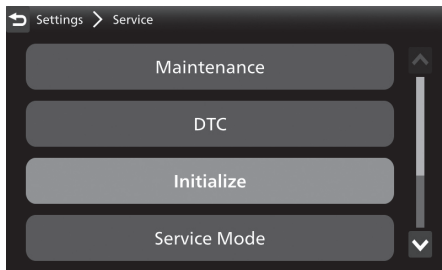

14. Select the “Initialize Quickshifter”.

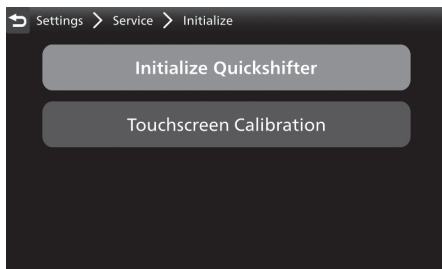

15. Select the “YES”.

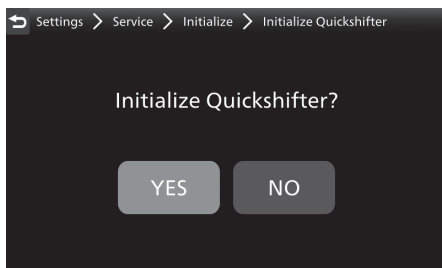

16. The display shown the message the “Preparing For Initialization”, then start the engine and it idle.

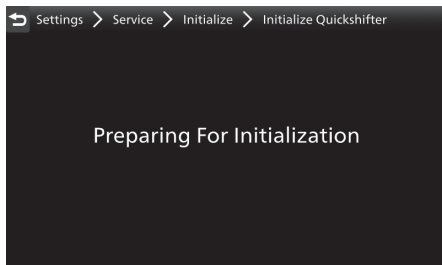

17. The display shown the message the “Shift to Neutral Position” the shift the transmission to the neutral position.

- **Do not operate throttle grip.**

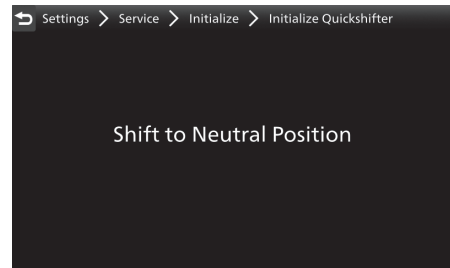

18. The display shown the message the “Do not touch the pedal.”

- **Do not touch the pedal.**

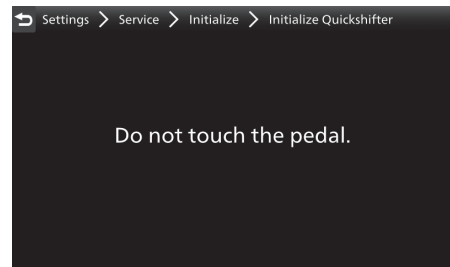

19. Wait for the display shows the message that “Initialization Succeeded”.

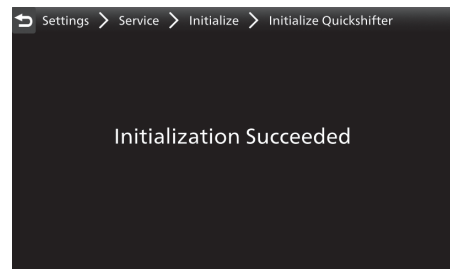

- **If the display shows the message that “Initialization Failed”, check the mounting conditions of the quick shifter, then restart the initialization again.**

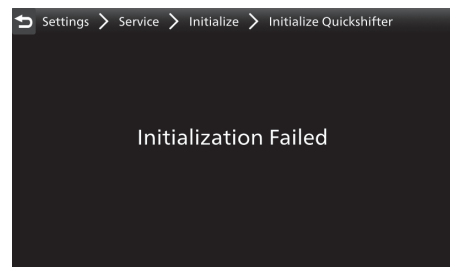

20. Turn the ignition switch OFF and remove the SCS short connector.

OPERATING INSTRUCTIONS

This accessory enable the shift change without clutch operation when shifting up and down during acceleration (Engine speed is more than 1,600 rpm on upshifting or more than the idle speed on downshifting).

- If the gear position display is not normal, the shift feeling may change.
- When the shift change do not operate normally, the shift change by clutch operation can be operated.

NOTE:

- **For setting the UP or DOWN sensitivity of the Quick Shifter, refer to the Genuine Accessory User's Guide.**