

# Computar Megapixel Objektiv AG6Z8516KCS-MP

6X 8.5mm-50mm F1.6  
for 1/2.7 type Megapixel Cameras, Vari-focal, Stepping Motor Iris  
CS-Mount

Model No.		AG6Z8516KCS-MP		Effective	Front	φ 21.7mm	
Focal Length		8.5mm - 50mm		Lens Aperture	Rear	φ 9.8mm	
Max. Aperture Ratio		1:1.6		Back Focal Length	Tele	9.4mm	
Max. Image Format		3.2mm x 5.8mm(φ 6.6mm)			Wide	10.7mm	
Operation Range	Iris	F1.6 - F16C		Flange Back Length		12.5mm	
	Focus	1.0m - Inf.		Mount		CS-Mount	
	Zoom	8.5mm - 50mm		Filter Size		M40.5 P=0.5mm	
Control	Iris	Stepping Motor		Dimensions		φ 46 mm x 60mm x 58.2 mm	
	Focus	Manual		Weight		78g	
	Zoom	Manual					
Angle of View	D	1/2.7 type (16:9)	43.7° - 7.7°	1/2.7 type (4:3)	43.7° - 7.7°	1/3 type (4:3)	39.7° - 7.1°
	H		38.0° - 6.8°		34.8° - 6.2°		31.6° - 5.7°
	V		21.3° - 3.9°		26.0° - 4.7°		23.7° - 4.3°
Operating Temperature		-10°C - +50°C					

## Dimensions

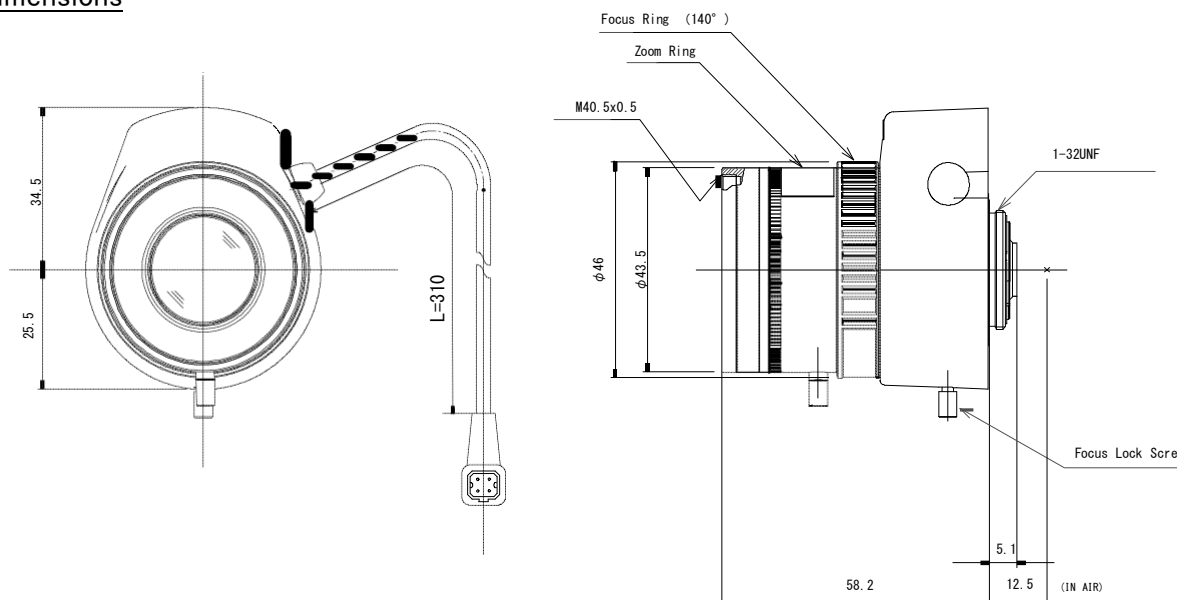

## Wiring Diagram

