

# Computar Megapixel Objektiv MG2514KC-MPIR

f=25mm F1.4 Day & Night  
for 2/3 type 5 Megapixel Cameras, Fixed-focal, Stepping Motor Iris  
C-Mount

Model No.	MG2514KC-MPIR		Effective	Front	φ 27.0mm		
Focal Length	25mm		Lens Aperture	Rear	φ 12.4mm		
Max. Aperture Ratio	1:1.4		Back Focal Length		10.8mm		
Max. Image Format	11.3mm x 6.0mm (φ 12.8mm)		Flange Back Length		17.526mm		
Operation Range	Iris	F1.4 - F16C		Mount	C-Mount		
	Focus	1m - Inf.		Filter Size	M40.5 × 0.5		
	Zoom	-		Dimensions	φ 42mm × 58.6mm × 53.9mm		
Control	Iris	Stepping Motor		Weight	128.8g		
	Focus	Manual					
	Zoom	-					
Angle of View	D	2/3 type	24.9°	1/2 type	18.2°	1/3 type	13.7°
	H		20.0°		14.6°		11.0°
	V		15.1°		11.0°		8.2°
Operating Temperature	-10°C - +50°C		CMV2000	D	28.6°		
			11.264 × 5.984	H	25.4°		
			(φ 12.75)	V	13.7°		

## Dimensions

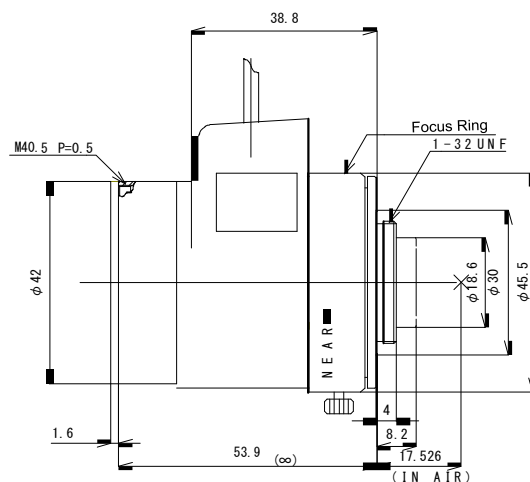
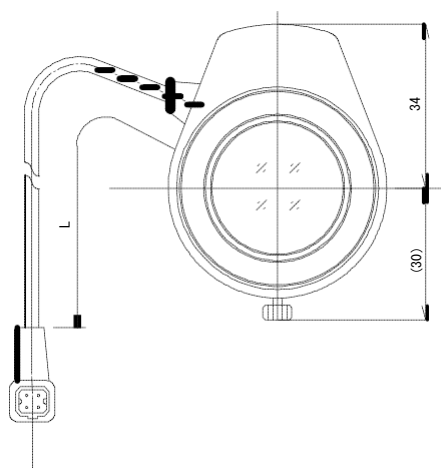

## Wiring Diagram

