



Hubbell Twist-Lock® Devices

**50A, 3 Phase 480V AC, 3 Pole, 4 Wire
Grounding Insulgrip® Plug**

Features

- Super tough nylon housing offers better impact qualities
- Stainless steel shroud protects contacts and prevents mismatching with the wrong device
- Heavy duty two-piece external cord clamp provides maximum strain relief
- Box terminal with hex socket threaded slug, permits high clamping pressure on conductors without damaging strands
- Thermoplastic polyester interior provides heat resistance and impact strength

Ordering Information

Description	Cord Diameter	Hubbell Number
Nylon cover, thermoplastic polyester interior	.830" - 1.250" (21.08 - 31.75 mm)	CS8165C

Stay Online Item # 6975

Listings

Listed to UL 498
Certified to CSA C22.2 No.42

Specifications

Housing	Nylon
Blade Holder	Polyester
Blades	Brass
Shell	Stainless Steel
Terminal Screws	Stainless Steel
Cord Grip	Polyester

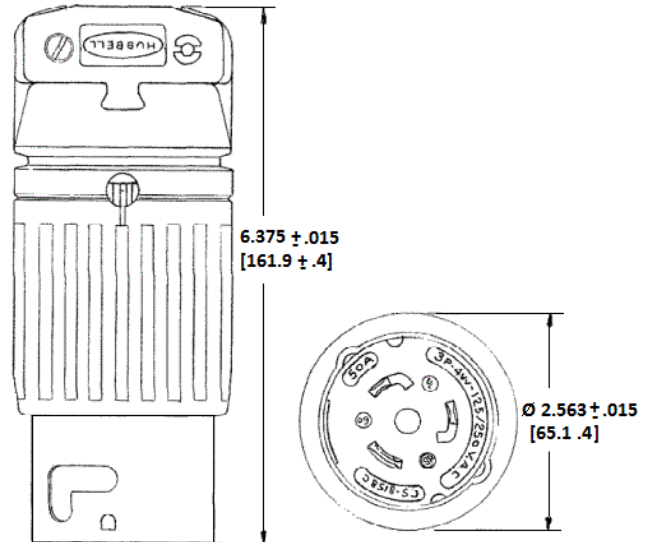

Performance

Electrical

Current Interrupting	Certified for current interrupting at full rated current
Dielectric Voltage	Withstands 2,000V minimum

Mechanical

Terminal Accommodation	#10 AWG - #6 AWG stranded copper wire only.
------------------------	---------------------------------------------

Environmental

Flammability	HB or better
Operating Temperatures	Maximum Continuous 75°C; Minimum -40°C (w/o impact)

Accessories

Connector	CS8164C
Single Receptacle	CS8169
Weatherproof Boot	HBL7716C