

Spare Parts List
Ersatzteilliste
Liste de pièces détachées
Lista de piezas de repuesto

2011-07

PB-250.4

PB-251.4 (USA)

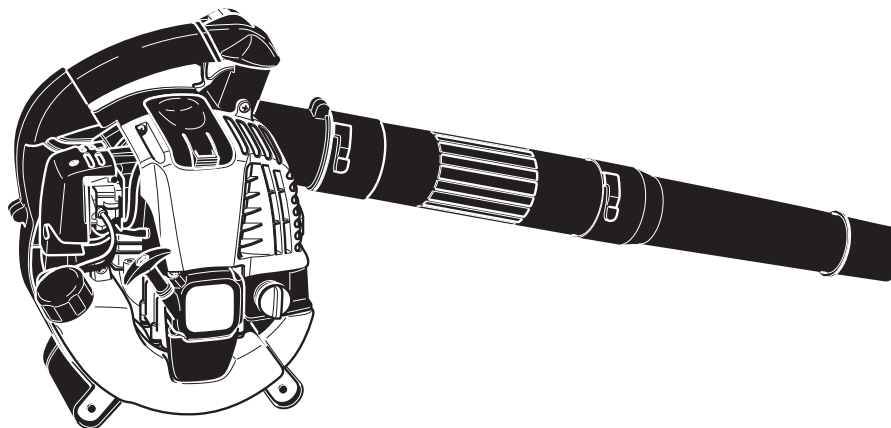

DOLMAR



A member of the *Makita* Group

995700259 (D, GB, F, E)

PB-250.4, PB-251.4

1

Gebälsegehäuse, Tank
Volute case, fuel tank
Carter de ventilateur, réservoir d'essence
Carcasa del ventilador, depósito de combustible

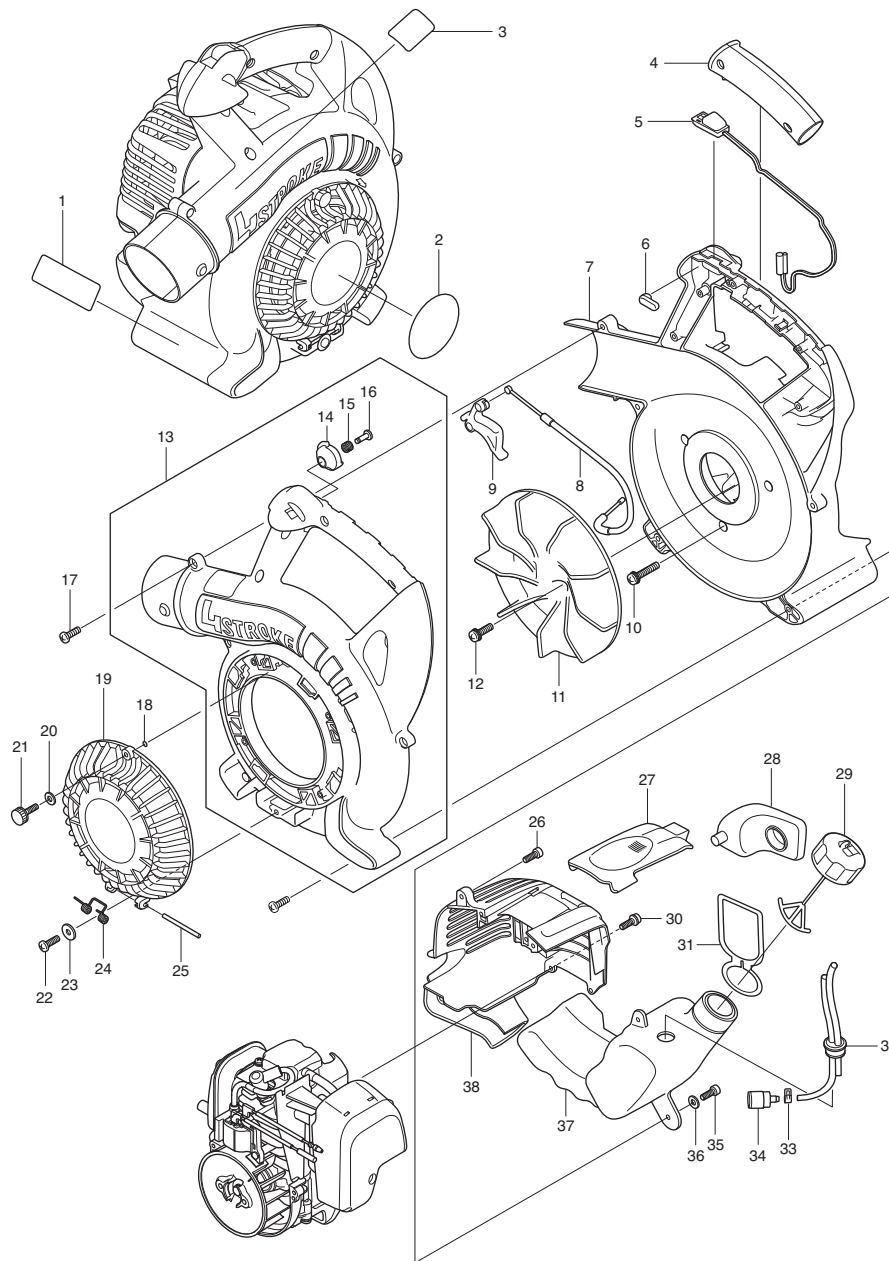

PB-250.4, PB-251.4

1

Gebläsegehäuse, Tank
Volute case, fuel tank
Carter de ventilateur, réservoir d'essence
Carcasa del ventilador, depósito de combustible

DOLMAR
A member of the **Takita** Group

Seite / Page	Pos.	PB-250.4	PB-251.4 (USA)	Teil-Nr. Part No. No. de pièce No. de pieza	Hinweise Notes Renseign. Nota	Bezeichnung	Spezifikation Specification	Description	Désignation	Denominación
1	1	1	1	388 628 998		SICHERHEITSAUFKLEBER		CAUTION LABEL	PANNEAU AVERTISSEUR	CHAPA DE AVISO
1	2	1	1	388 950 240		AUFKLEBER		PROTECTOR LABEL	PLAQUE	CALCOMANIA
1	3	1	1	388 951 320		SICHERHEITSAUFKLEBER		CAUTION LABEL	PLAQUE	CALCOMANIA
1	4	1	1	388 550 000		HANDGRIFF		GRIP	POIGNÉE	MANGO
1	5	1	1	388 500 100		SCHALTER KPL.		SWITCH COMPL	INTERRUPTEUR	INTERRUPTOR
1	6	1	1	367 150 050		GUMMIPUFFER		FRICTION PUBBER	TAMPON EN CAOUTCHOUC	TOPE DE CAUCHO
1	7	1	1	388 101 400		GEBLÄSEGEHÄUSE 2 KPL.		VOLUTE CASE 2 COMPL	CARTER DE VENTILATEUR 2 CPL.	CARCASA DEL VENTILADOR 2 CPL.
1	8	1	1	388 002 973		BOWDENZUG		CONTROL CABLE	CÂBLE BOWDEN	TRACCIÓN BOWDEN
1	9	1	1	388 550 030		GASHEBEL		THROTTLE LEVER	LEVIER DE GAZ	PALANCA DE GAS
1	10	3	3	388 360 530		SCHRAUBE KPL.		SCREW ASS'Y	VIS CPL.	TORNILLO CPL.
1	11	1	1	388 100 300		GEBLÄSERAD KPL.		IMPELLER COMPL	ROUE DE VENTILATEUR CPL.	RUEDA DE VENTILADOR CPL.
1	12	2	2	377 360 620		SCHRAUBE KPL.	M6X20	SCREW	VIS CPL.	TORNILLO CPL.
1	13	1	1	388 101 000		GEBLÄSEGEHÄUSE 1 KPL.	INC.14-16	VOLUTE CASE 1 ASSY	CARTER DE VENTILATEUR 1 CPL.	CARCASA DEL VENTILADOR 1 CPL.
1	14	1	1	388 550 010		RASTHEBEL		CRUISE LEVER	LEVIER DE VERROUILLAGE	PALANCA TRINCADA
1	15	1	1	388 550 020		FEDER		SPRING	RESSORT	MUELLE
1	16	1	1	388 004 984		SCHNEIDSCHRAUBE	4X16	TAPPING SCREW	VIS DE COUPE	TORNILLO DE ROSCA CORTANTE
1	17	10	10	381 005 976		SCHNEIDSCHRAUBE	5X16	TAPPING SCREW	VIS TARAUDEUSE	TORNILLO DE ROSCA CORTANTE
1	18	1	1	377 150 340		SICHERUNGSRING		OUTER SNAPRING	CIRCLIP	ANILLO
1	19	1	1	377 150 270		SCHUTZGITTER		PROTECTION GRILL	GRILLE DE PROTECTION	REJILLA DE PROTECCIÓN
1	20	1	1	377 150 350		GUMMISCHEIBE		RUBBER WASHER	RONDELLE EN CAOUTCHOUC	ARANDELA DE GOMA
1	21	1	1	377 150 320		SCHRAUBE		SCREW	VIS	TORNILLO
1	22	1	1	381 005 976		SCHNEIDSCHRAUBE	5X16	TAPPING SCREW	VIS TARAUDEUSE	TORNILLO DE ROSCA CORTANTE
1	23	1	1	388 120 500		SCHEIBE		WASHER	RONDELLE	ARANDELA
1	24	1	1	377 150 300		FEDER		SPRING	RESSORT	MUELLE
1	25	1	1	377 150 310		ACHSE		SHAFT	BROCHE	PERNO
1	26	3	3	381 005 976		SCHNEIDSCHRAUBE	5X16	TAPPING SCREW	VIS TARAUDEUSE	TORNILLO DE ROSCA CORTANTE
1	27	1	1	381 650 010		KERZENABDECKUNG		PLUG COVER	COUVERCLE P. BOUGIE	TAPA DE BUJIA
1	28	1	1	388 650 160		GUMMISCHUTZ		OIL GUARD	PROTECTION EN CAOUTCHOUC	PROTECCIÓN DE CAUCHO
1	29	1	1	367 125 472		KRAFTSTOFFTANKDECKEL KPL.		FUEL TANK CAP ASSEMBLY	BOUCHON RESERV. CPL., CARB.	TORNILLO DE CIERRE CPL., COMB.
1	30	2	2	367 911 128		FLACHKOPFSCHRAUBE	M4x16	PAN HEAD SCREW	VIS À TÊTE CYLINDRIQUE	TORNILLO DE CABEZA PLANA
1	31	1	1	367 950 150		HINWEISSCHILD F.KRAFTSTOFFART		STRAP	PLAQUE POUR TYPE DE CARBURANT	ETIQUETA DE INDICACIÓN
1	32	1	1	388 118 995		SCHLAUCH		TUBE	TUYAU SOUPLE	TUBO FLEXIBLE
1	33	1	1	381 105 999		SCHLAUCHKLEMME		HOSE CLAMP	COLLIER	ABRAZADERA
1	34	1	1	320 163 447		BENZINFILTER		GASOLIN FILTER	FILTRE D'ESSENCE	FILTRO DE GASOLINA
1	35	3	3	381 005 976		SCHNEIDSCHRAUBE	5X16	TAPPING SCREW	VIS TARAUDEUSE	TORNILLO DE ROSCA CORTANTE
1	36	3	3	388 100 500		SCHEIBE		WASHER	RONDELLE	ARANDELA
1	37	1	1	388 350 000		KRAFTSTOFFTANK		FUEL TANK	RESERVOIR D'ESSENCE	DEPÓSITO DE COMBUSTIBLE
1	37	1	1	382 350 011		KRAFTSTOFFTANK	USA-CA	FUEL TANK	RESERVOIR D'ESSENCE	DEPÓSITO DE COMBUSTIBLE
1	38	1	1	388 650 040		MOTORGEHÄUSE		ENGIN COVER	CARTER MOTEUR	CÁRTER MOTOR
1	38	1	1	377 452 671	EU	MOTORGEHÄUSE	DOLMAR, EU: FROM 2010-08	ENGINE COVER	CARTER MOTEUR	CÁRTER MOTOR

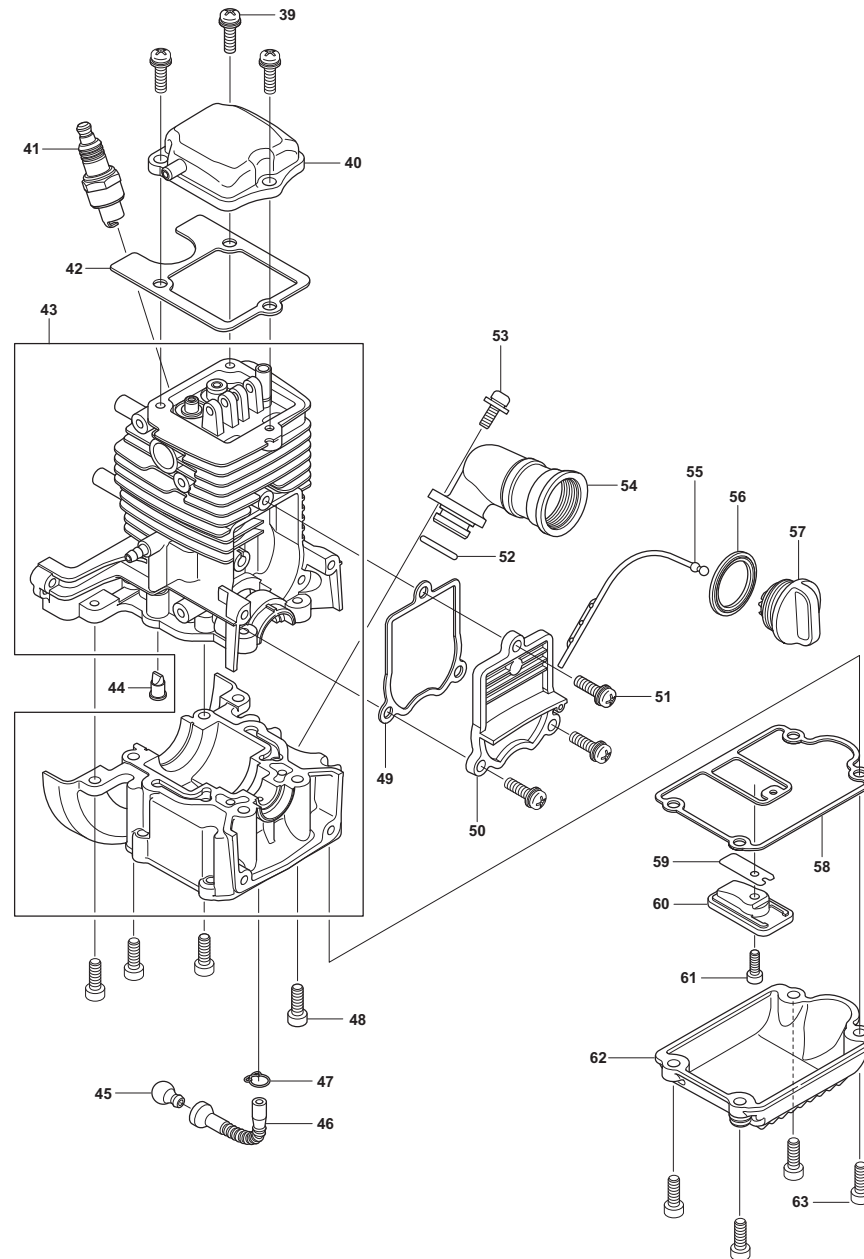

PB-250.4, PB-251.4

2

Kurbelgehäuse, Zylinder, Ölwanne
Crankcase, cylinder, oil case
Carter-vilebrequin, cylindre, cuvette a huile
Carter cigüeñal, cilindro, carter de aceite

DOLMAR
A member of the **Takita** Group

Seite / Page	Pos.	PB-250.4	PB-251.4 (USA)	Teil-Nr. Part No. No. de pièce No. de pieza	Hinweise Notes Renseign. Nota	Bezeichnung	Spezifikation Specification	Description	Désignation	Denominación
2	39	3	3	367 905 953		SCHRAUBE	M5X16(W,SW)	SOCKET HEAD BOLT	VIS	TORNILLO
2	40	1	1	367 100 400		ABDECKUNG F.KIPPHEBEL		ROCKER COVER COMPLETE	CAPOT POUR CULBUTEUR	TAPA DE BALANCINES CPL
2	41	1	1	367 010 995		ZÜNDKERZE		SPARK PLUG	BOUGIE	BUJIA
2	42	1	1	367 162 275		DICHTUNG, ABDECKUNG F.KIPPHEBEL		ROCKER COVER GASKET	JOINT, CAPOT POUR CULBUTEUR	JUNTA, TAPA DE BALANCINES CPL
2	43	1	1	388 125 914		ZYLINDERBLOCK SATZ	2008-08 =>	CYLINDER BLOCK SET	BLOC DE CYLINDRES	BLOQUE DE CILINDROS
2	43	1	1	381 101 100		ZYLINDERBLOCK SATZ	=> 2008-07	CYLINDER BLOCK SET	BLOC DE CYLINDRES	BLOQUE DE CILINDROS
2	44	2	2	367 150 180		RÜCKSCHLAGVENTIL		CHECK VALVE	SOUPAPE DE RETENU	VÁLVULA ANTIRRETORNO
2	45	1	1	367 650 030		GEWICHT F.ÖLLEITUNG		OIL WEIGHT	POIDS POUR TUYAU D'HUILE	PESA PARA EL TUBO DEL ACEITE
2	46	1	1	367 650 020		ÖLLEITUNG		OIL TUBE	TUBE D'HUILE	TUBO DE ACEITE
2	47	1	1	388 105 997		SCHLAUCHKLEMME		HOSE CLAMP	COLLIER	ABRAZADERA
2	48	8	8	367 905 951		SCHRAUBE	M5X14	SOCKET HEAD BOLT	VIS	TORNILLO
2	49	1	1	367 162 274		DICHTUNG		CAM GEAR COVER GASKET	JOINT	JUNTA
2	50	1	1	383 150 050		ABDECKUNG F.NOCKENRAD		CAMGEAR COVER	CAPOT	TAPA D. PIÑÓN D. ÁRB. DE LEV.
2	51	3	3	367 905 951		SCHRAUBE	M5X14	SOCKET HEAD BOLT	VIS	TORNILLO
2	52	1	1	388 013 995		O-RING		O RING	BAGUE-JOINT	ANILLO DE GUARNICIÓN
2	53	1	1	994 005 127		SCHRAUBE	M5x12	SOCKET HEAD BOLT	VIS	TORNILLO
2	54	1	1	388 140 813		ÖLLEITUNG KPL.		OIL PIPE COMPL	TUBE D'HUILE	TUBO DE ACEITE
2	55	1	1	388 650 170		ÖLPEILSTAB		OIL GAUGE	GAUGE D'HUILE	INDICADOR DEL NIVEL DE ACEITE
2	56	1	1	388 322 999		DICHTUNG		GASKET	JOINT	JUNTA
2	57	1	1	388 650 150		ÖLDECKEL		OIL CAP	BOUCHON	TAPA
2	58	1	1	367 162 276		DICHTUNG		CASE GASKET	JOINT	JUNTA
2	59	1	1	367 150 100		EINLASSMEMBRAN (REEDVALVE)		LEAD VALVE	MEMBRANE D'ADMISSION	VÁLVULA CON MEMBRANA DE ADMISIÓN
2	60	1	1	367 150 110		STOPPER F.REEDVALVE		RETAINER PLATE	FILTRE EN FEUTRE	FILTRO DE FIELTRO
2	61	1	1	367 922 112		6KT-SCHRAUBE	M4X10	HEX. SOCKET HEAD BOLT	VIS HEXAGONAL	TORNILLO HEXAGONAL
2	62	1	1	367 650 000		ÖLWANNE		OIL CASE	CUVETTE A HUILE	CÁRTER DE ACEITE
2	63	4	4	367 905 951		SCHRAUBE	M5X14	SOCKET HEAD BOLT	VIS	TORNILLO

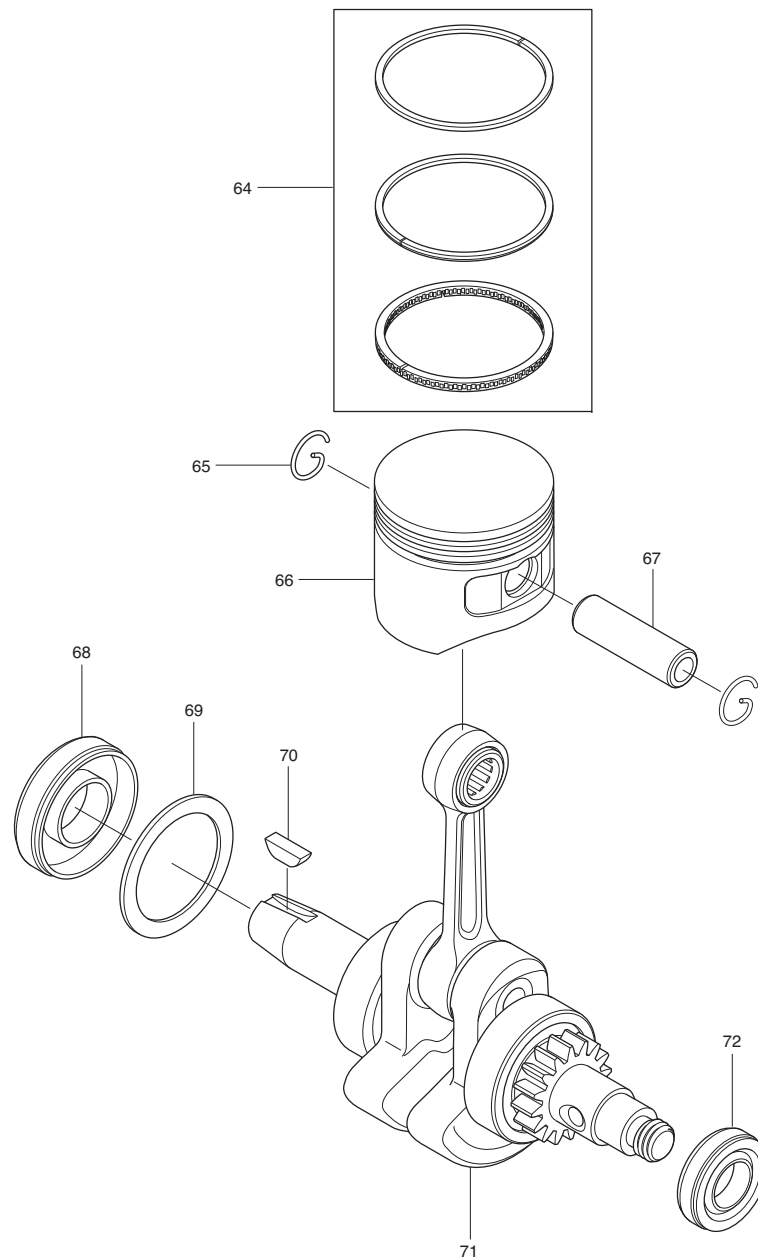

PB-250.4, PB-251.4

3

Kurbelwelle, Kolben
Crankshaft, piston
Vilebrequin, piston
Cigüeñal, pistón**DOLMAR**A member of the **Takita** Group

Seite / Page	Pos.	PB-250.4	PB-251.4 (USA)	Teil-Nr. Part No. No. de pièce No. de pieza	Hinweise Notes Renseign. Nota	Bezeichnung	Spezifikation Specification	Description	Désignation	Denominación
3	64	1	1	367 200 400		KOLBENRING-SATZ		PISTON RING SET	JEU DE SEGMENTS DE PISTON	JUEGO DE SEGMENTOS DEL PISTÓN
3	65	2	2	367 233 976		SPRENGRING		CLIP	ANNEAU RESSORT	ANILLO ELÁSTICO
3	66	1	1	367 250 090		KOLBEN		PISTON	PISTON	PISTÓN
3	67	1	1	367 257 781		KOLBENBOLZEN		PISTON PIN	AXE DE PISTON	BULÓN DEL PISTÓN
3	68	1	1	367 012 996		RADIALDICHRING	(L)	OIL SEAL	JOINT RADIAL	JUNTA RADIAL
3	69	1	1	381 150 050		DISTANZRING		CLIP	DOUILLE DE DISTANCE	CASQUILLO SEPARADOR
3	70	1	1	367 254 040		SCHEIBENFEDER	3	WOODRUFF KEY	CLAVETTE	CHAVETA
3	71	1	1	367 200 300		KURBELWELLE KPL.		CRANK SHAFT ASS'Y	ARBRE-MANIVELLE COMPLET	GRUPO DEL CIGÜEÑAL
3	72	1	1	367 213 148		ÖLDICHTUNG	10	OIL SEAL	JOINT ÉTANCHE À L'HUILE	RETÉN DE ACEITE

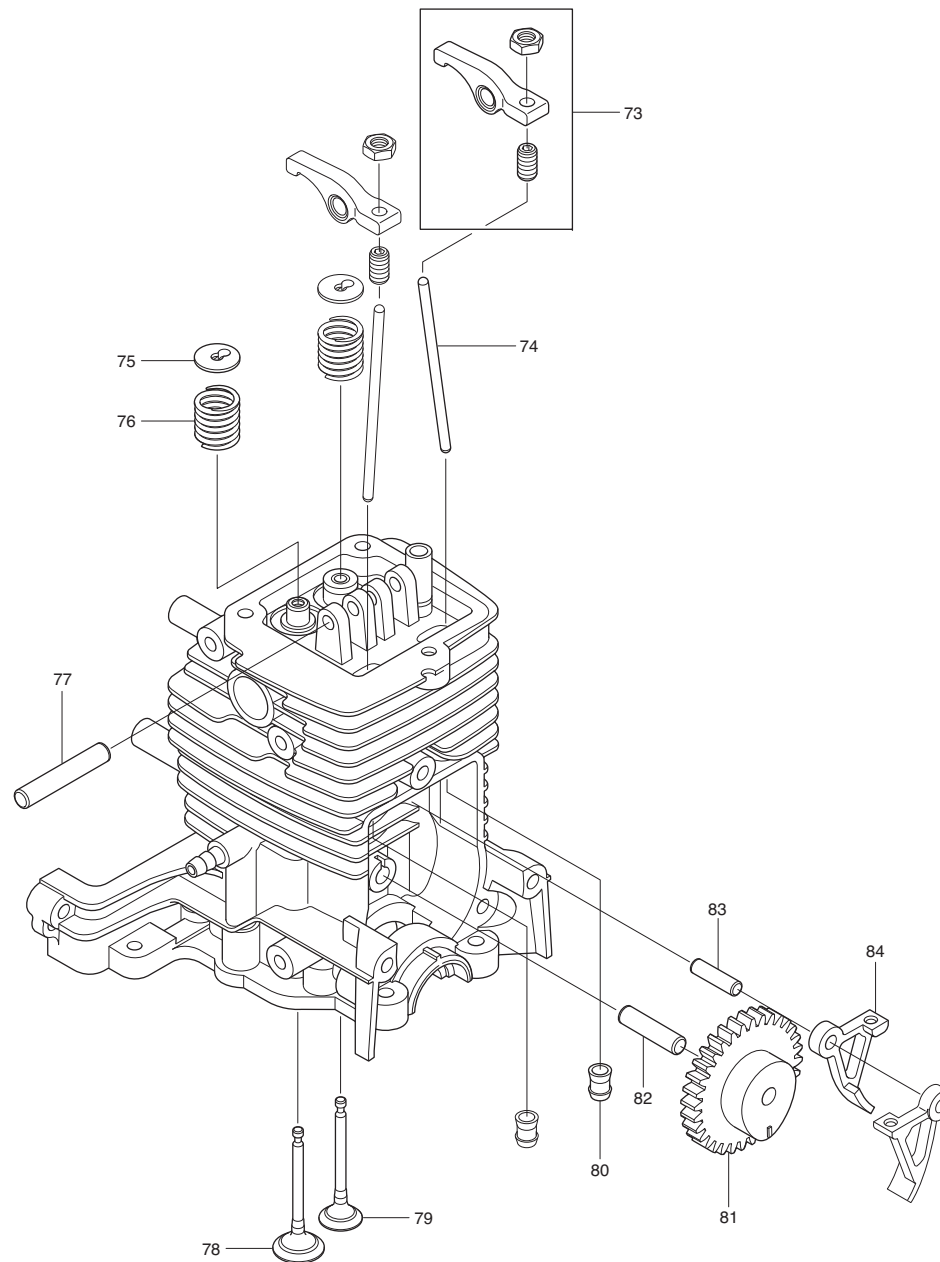

PB-250.4, PB-251.4

4

Nockenrad, Ventile
Cam gear, valves
Pignon de distribution, soupapes
Grupo del árbol de levas, válvulas

DOLMAR
A member of the **Takita** Group

Seite / Page	Pos.	PB-250.4	PB-251.4 (USA)	Teil-Nr. Part No. No. de pièce No. de pieza	Hinweise Notes Renseign. Nota	Bezeichnung	Spezifikation Specification	Description	Désignation	Denominación
4	73	2	2	374 300 200		KIPPEBEL		ROCKER ARM ASS'Y	CULBUTEUR	GRUPO DEL BALANCÍN
4	74	2	2	367 350 070		STÖßELSTANGE		PUSH ROD	TIGE DE CULBUTEUR	EMPUJADOR
4	75	2	2	367 350 130		FEDERTELLER		SPRING RETAINER	CUVETTE DE RESSORT	CAJA DE RESORTE
4	76	2	2	367 350 120		VENTILFEDER		VALVE SPRING	RESSORT DE VANNE	MUELLE DE VÁLVULA
4	77	1	1	367 350 010		ACHSE FÜR KIPPEBEL		ROCKER SHAFT	AXE DE CULBUTEUR	EJE DE BALANCINES
4	78	1	1	367 350 150		EINLASSVENTIL		INTAKE VALVE	VALVE D'ADMISSION	VÁLVULA DE ADMISIÓN
4	79	1	1	367 350 140		AUSLASSVENTIL		EXHAUST VALVE	SOUPAPE D'EMISSION	VÁLVULA DE ESCAPE
4	80	2	2	367 150 140		DICHTSTOPFEN		SPACER	BOUCHON	SEPARADOR
4	81	1	1	382 300 300		NOCKENRAD		CAM GEAR ASS'Y	PIGNON DE DISTRIBUTION	GRUPO DEL ÁRBOL DE LEVAS
4	82	1	1	367 350 050		ACHSE F.NOCKENRAD		CAM GEAR SHAFT	AXE DE PIGNON DE DISTRIBUTION	EJE D. PIÑÓN D. ÁRB. DE LEV.
4	83	1	1	367 350 060		ACHSE F.NOCKENHEBEL		CAM LIFTER SHAFT	AXE DE LEVIER	ÁRBOL DE LEVAS
4	84	2	2	367 350 000		NOCKENHEBEL		CAM LIFTER	LEVIER A CAMES	LEVAS

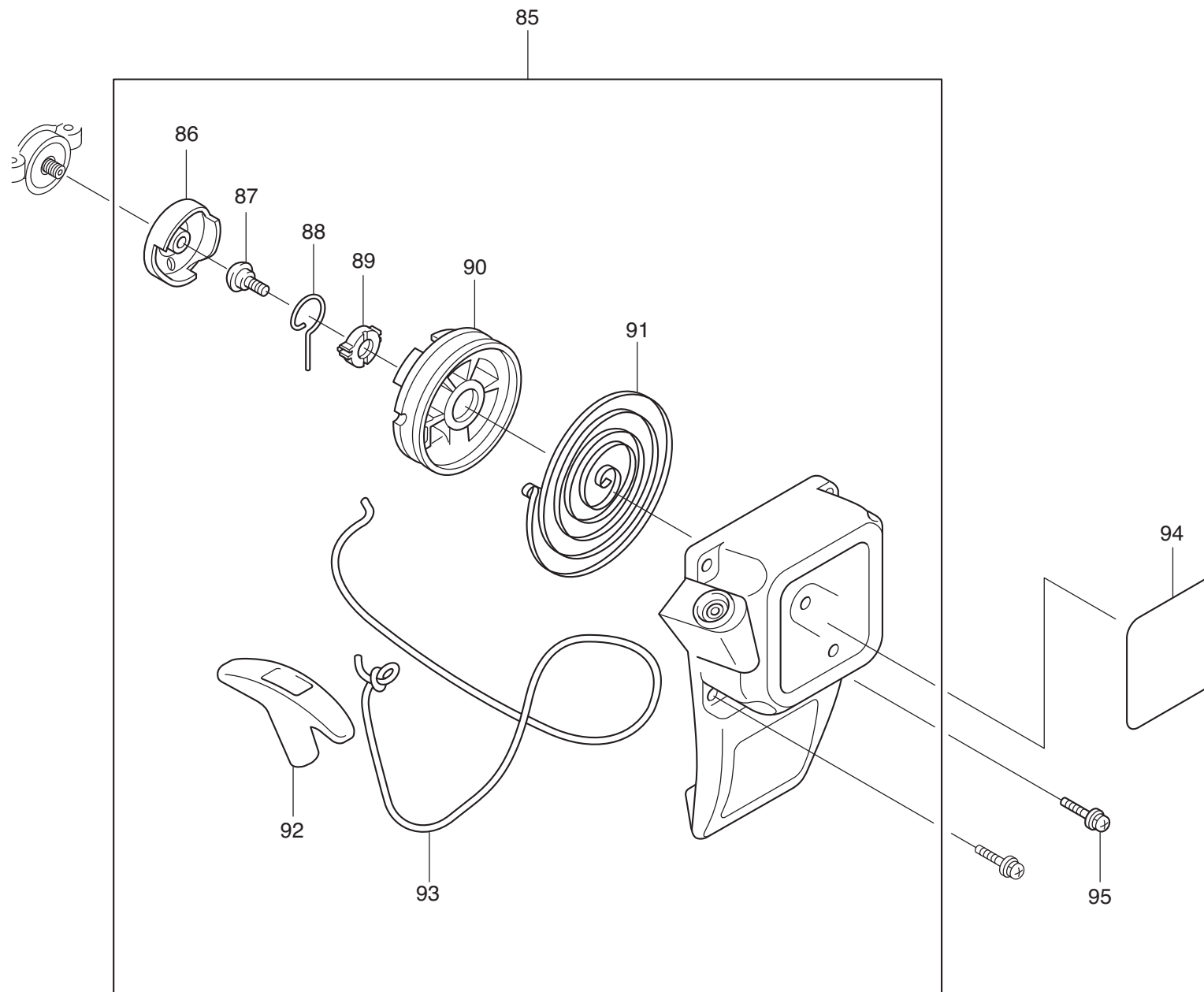

PB-250.4, PB-251.4

5

Starter
Starter
Dispositif de démarrage
Dispositivo de arranque

DOLMAR
A member of the **Takita** Group

Seite / Page	Pos.	PB-250.4	PB-251.4 (USA)	Teil-Nr. Part No. No. de pièce No. de pieza	Hinweise Notes Renseign. Nota	Bezeichnung	Spezifikation Specification	Description	Désignation	Denominación
5	85	1	1	367 500 100		STARTER KPL.		STARTER COVER ASS'Y	DÉMARREUR COMPLET	ARRANCADOR CPL.
5	86	1	1	367 550 000		STARTERRAD		PULLEY	ROUE DÉMARREUR	RUEDA DE ARRANQUE
5	87	1	1	367 266 585		BLECHSCHRAUBE	5X12	TAPPING SCREW	VIS TARAUEUSE	TORNILLO DE ROSCA CORTANTE
5	88	1	1	367 500 210		MITNEHMERBÜGEL		SWING ARM	ETRIER D'ENTRAÎNEMENT	BRAZO OSCILANTE
5	89	1	1	367 500 211		AUFNAHME F. MITNEHMERBÜGEL		COLLAR	LOGEMENT POU ETRIER	ANILLO DE RETENCIÓN
5	90	1	1	367 500 103		SEILTROMMEL		REEL	TAMBOUR DE CÂBLE	TAMBOR PARA CUERDA
5	91	1	1	381 500 203		RÜCKHOLFEDER		SPIRAL SPRING	RESSORT DE RAPPEL	RESORTE RETENCION
5	92	1	1	367 424 319		ANWERFGRIF		STARTER KNOB	POIGNÉE DE LANCEMENT	TIRADOR DE ARRANQUE
5	93	1	1	367 500 105		ANWERFSEIL	ø2,8	STARTER ROPE	CÂBLE DÉMARRAGE	CORDÓN DE ARRANQUE
5	94	1	1	388 950 250		SCHILD		MODEL LABEL	PLAQUE	PLACA
5	95	2	2	367 911 128		FLACHKOPFSCHRAUBE	M4x16	PAN HEAD SCREW	VIS À TÊTE CYLINDRIQUE	TORNILLO DE CABEZA PLANA

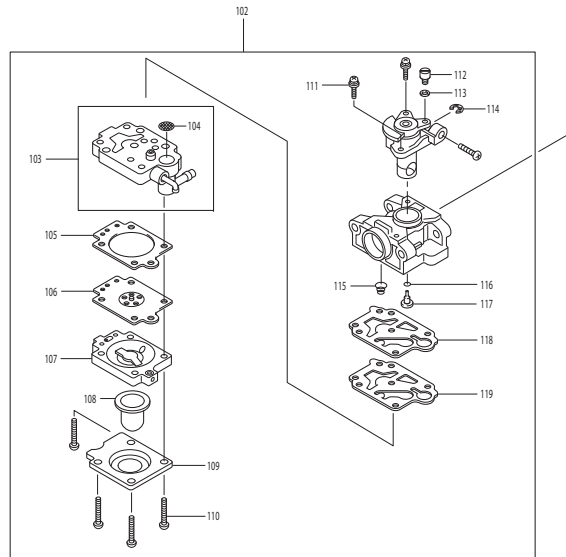
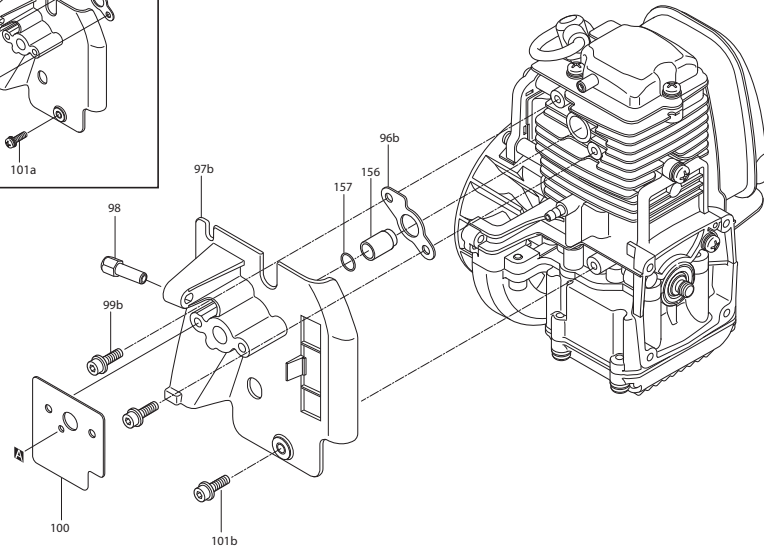
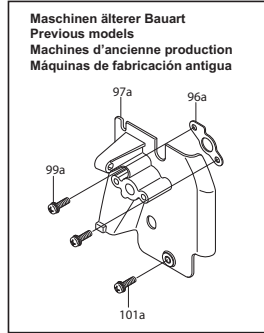

PB-250.4, PB-251.4

6

Vergaser
Carburetor
Carburateur
Carburador



 A member of the **Takita** Group

Seite / Page	Pos.	PB-250.4	PB-251.4 (USA)	Teil-Nr. Part No. No. de pièce No. de pieza	Hinweise Notes Renseign. Nota	Bezeichnung	Spezifikation Specification	Description	Désignation	Denominación
6	96a	1	1	367 350 180		DICHTUNG		INSULATOR GASKET	JOINT	JUNTA
6	96b	1	1	382 350 470		DICHTUNG F. ZWISCHENFLANSCH		INSULATOR GASKET	JOINT	JUNTA
6	97a	1	1	381 301 300		ZWISCHENFLANSCH		INSULATOR COMPL	PLAQUE DE FILTRE A AIR	PLANCHA DEL FILTRO DE AIRE CPL
6	97b	1	1	388 125 916		ZWISCHENFLANSCH KPL.		INSULATOR ASS'Y	BRIDE INTERMÉDIAIRE	BRIDA INTERMEDIA
6	98	1	1	367 325 934		STELLSCHRAUBE		ADJUST SCREW	VIS DE REGLAGE	TORNILLO DE AJUSTE
6	99a	2	2	381 360 518		SCHRAUBE	M5X18	SCREW ASS'Y.	VIS	TORNILLO
6	99b	2	2	381 905 987		SCHRAUBE	M5X18	SOCKET HEAD BOLT	VIS	TORNILLO
6	100	1	1	367 413 138		DICHTUNG		CARBURETOR GASKET	JOINT	JUNTA
6	101a	1	1	367 360 514		SCHRAUBE KPL.	M5X14	SCREW ASS'Y	VIS CPL.	TORNILLO CPL.
6	101b	1	1	994 005 127		SCHRAUBE	M5x12	SOCKET HEAD BOLT	VIS	TORNILLO
6	102	1	1	388 602 201		VERGASER	WYL218A	CARBURETOR	CARBURATEUR	CARBURADOR
6	103	1	1	388 140 808		PUMPENKÖRPER KPL.		PUMP BODY ASS'Y	POMPE CPL.	BOMBA CPL.
6	104	1	1	367 352 010		SIEB		INLET SCREEN	TAMIS	TAMIZ
6	105	1	1	367 442 154		DICHTUNG		METERING DIAPHRAGM GASKET	JOINT	JUNTA
6	106	1	1	374 600 901		STEUERMENBRANE		METERING DIAPHRAGM ASS'Y	MEMBRANE DE COMM.JEU	MEMBRANAS DE MANDO JUEGO
6	107	1	1	374 604 614		PRIMERSOCKEL		AIR PURGE BODY ASS'Y	SOCLE PRIMER	ZÓCALO PRIMER
6	108	1	1	367 424 314		PRIMER PUMPE		PRIMER PUMP	POMPE PRIMER	BOMBA PRIMER
6	109	1	1	374 604 605		PRIMERDECKEL		PRIMER PUMP COVER	COUVERCLE DE POMPE PRIMER	TAPA DEL PRIMARIO
6	110	4	4	367 266 582		BLECHSCHRAUBE	3X24	TAPPING SCREW	VIS TARAUDEUSE	TORNILLO DE ROSCA CORTANTE
6	111	2	2	388 600 803		ZYL.SCHRAUBE		SCREW	VIS CYLINDRIQUE	TORNILLO DE LA CULATA
6	112	1	1	367 325 922		NOCKEN		SWIVEL	CAME	LEVA
6	113	1	1	367 600 503		SCHEIBE		WASHER	DISQUE	ARANDELA
6	114	1	1	367 257 964		SICHERUNGSRING	E-3	STOP RING	CIRCLIP	ANILLO SEGURIDAD
6	115	1	1	367 234 183		DRUCKFEDER	5-9	CONICAL COMPRESSION SPRING	RESSORT DE PRESSION	MUELLE DE COMPRESIÓN
6	116	1	1	367 213 538		O-RING	2	O RING	ANNEAU TORIQUE	ANILLO OBTURADOR
6	117	1	1	374 606 501		DÜSE		JET	BUSE	CHICLÉ
6	118	1	1	367 442 155		PUMPENDICHTUNG		PUMP GASKET	JOINT	JUNTA
6	119	1	1	367 168 575		PUMPENMEMBRANE		PUMP DIAPHRAGM	MEMBRANE DE POMPE	MEMBRANAS DE LA BOMBA
6	156	1	1	381 350 460		ANSAUGROHR		INTAKE PIPE	TUYAU	TUBO
6	157	1	1	381 261 010		O-RING		O-RING	BAGUE JOINT	ANILLO DE GUARNICIÓN

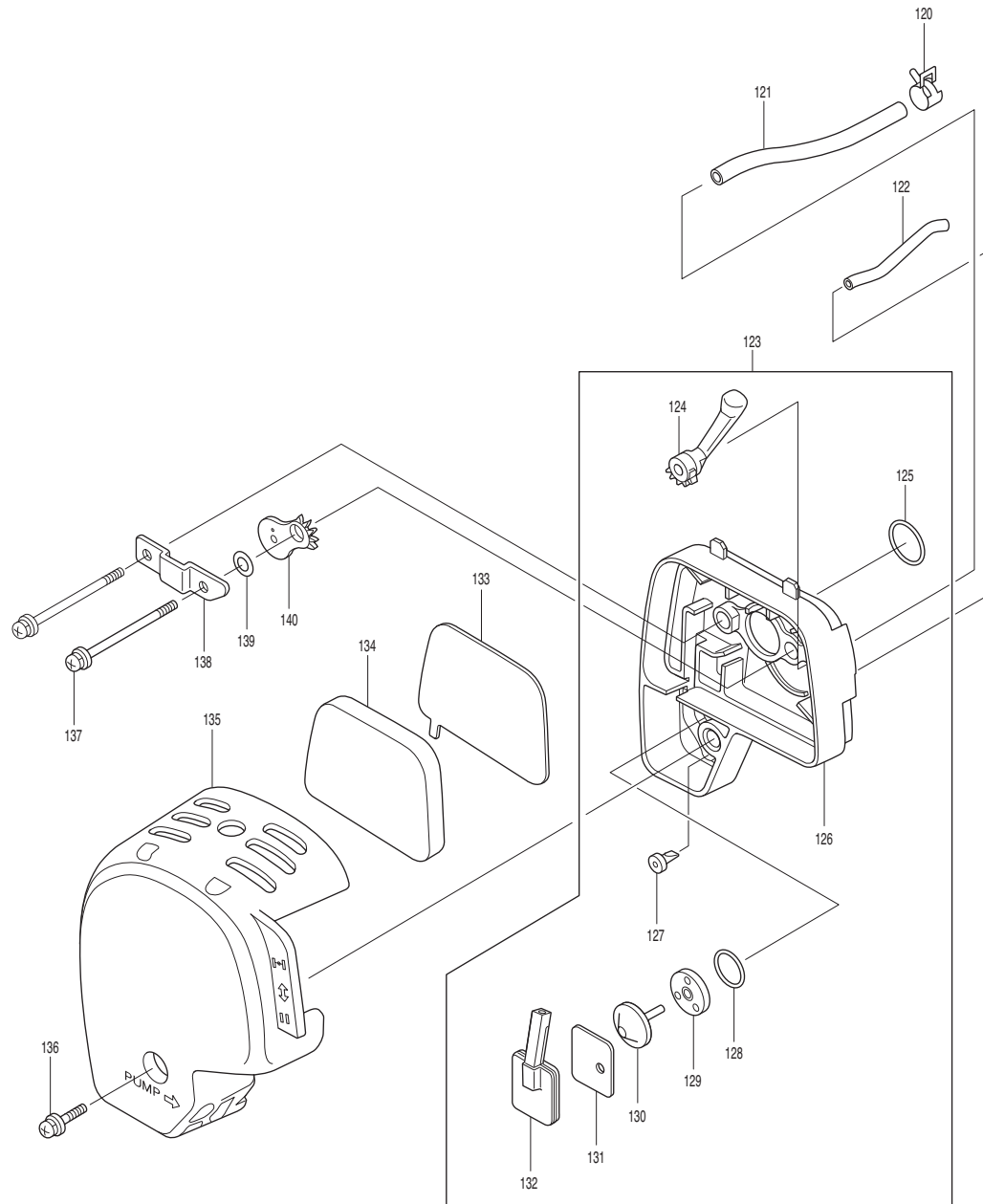

PB-250.4, PB-251.4

7

Luftfilter
Air cleaner
Filtre à air
Filtro de aire



 A member of the **Takita** Group

Seite / Page	Pos.	PB-250.4	PB-251.4 (USA)	Teil-Nr. Part No. No. de pièce No. de pieza	Hinweise Notes Renseign. Nota	Bezeichnung	Spezifikation Specification	Description	Désignation	Denominación
7	120	1	1	382 108 001		SCHLAUCHKLEMME		HOSE CLAMP	COLLIER	ABRAZADERA
7	121	1	1	367 150 090		ENTLÜFTUNGSSCHLAUCH	ø8/4x150	BREATHER PIPE	TUYAU DE PURGE	TUBO DE PURGA
7	122	1	1	374 350 210		ROHR		PIPE	TUBE	TUBO
7	123	1	1	374 300 100		LUFTFILTERBODEN KPL.		CLEANER PLATE ASS'Y	PLAQUE DE FILTRE A AIR CPL.	GRUPO DE LA PLANCHA DEL FILTRO
7	124	1	1	367 451 925		CHOKEHEBEL		CHOKE LEVER	LEVIER DE STARTER	PALANCA ESTRANGULADOR DE AIRE
7	125	1	1	367 015 999		O-RING		O RING	BAGUE-JOINT	JUNTA TÓRICA
7	126	1	1	374 300 500		LUFTFILTERPLATTE		AIR CLEANER PLATE	PLAQUE DE FILTRE A AIR	PLACA DE FILTRO DE AIR
7	127	1	1	367 424 316		RÜCKSCHLAGVENTIL		CHECK VALVE	SOUPAPE DE RETENU	VÁLVULA ANTIRRETORNO
7	128	1	1	367 013 997		O-RING		O RING	BAGUE-JOINT	JUNTA TÓRICA
7	129	1	1	367 350 250		VENTILSITZ		VALVE SEAT	SIÈGE DE SOUPAPE	ASIENTO DE VÁLVULA
7	130	1	1	367 424 315		RÜCKSCHLAGVENTIL		CHECK VALVE	SOUPAPE DE RETENU	VÁLVULA ANTIRRETORNO
7	131	1	1	367 350 350		DICHTUNG		GASKET SEPARATOR	JOINT	JUNTA
7	132	1	1	367 350 161		ÖLSEPARATOR		SEPARATOR PLATE	SÉPARATEUR D'HUILE	SEPARADOR DEL ACEITE
7	133	1	1	367 443 140		LUFTFILTER		ELEMENT AIR CLEANER	FILTRE À AIR	FILTRO DE AIRE
7	134	1	1	367 443 141		LUFTFILTER		ELEMENT AIR CLEANER	FILTRE À AIR	FILTRO DE AIRE
7	135	1	1	367 450 561		LUFTFILTERDECKEL		AIR CLEANER COVER	COUVERCLE DE FILTRE A AIR	CUBIERTA DEL FILTRO DE AIRE
7	136	1	1	221 233 160		SCHRAUBE	M5x14	SCREW	VIS	TORNILLO
7	137	2	2	367 350 310		SCHRAUBE	M5X68 (W,SW SUS)	SCREW	VIS	TORNILLO
7	138	1	1	367 350 260		SHELLE		PLATE	COLLIER	ABRAZADERA
7	139	1	1	367 423 376		DICHTUNG		GASKET	JOINT	JUNTA
7	140	1	1	367 450 560		CHOKEKLAPPE		CHOKE PLATE	CLAPET DE STARTER	TAPA DEL CHOKE

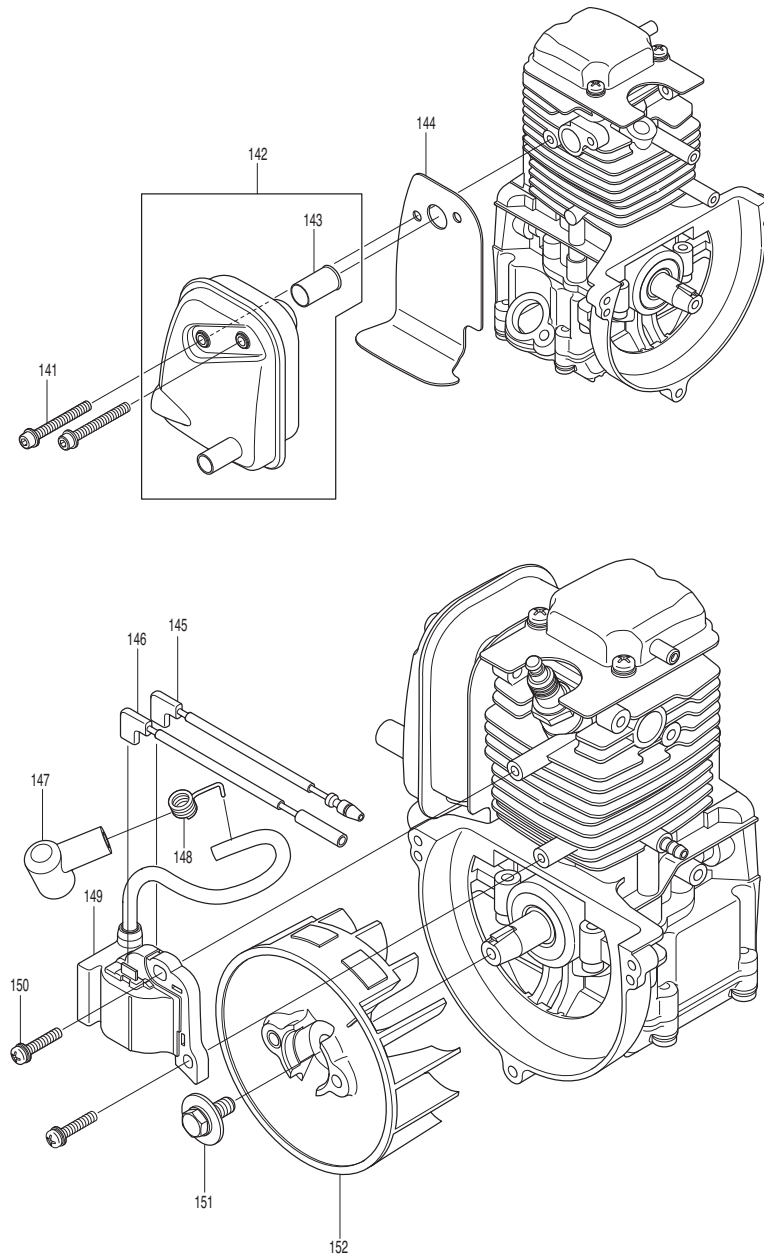

PB-250.4, PB-251.4

8

Zündung, Polrad, Schalldämpfer
 Ignition, flywheel, exhaust muffler
 Bobine d'allumage, roue polaire, pot d' échappement
 Bobina encend, volante encend, silencioso

DOLMARA member of the **Takita** Group

Seite / Page	Pos.	PB-250.4	PB-251.4 (USA)	Teil-Nr. Part No. No. de pièce No. de pieza	Hinweise Notes Renseign. Nota	Bezeichnung	Spezifikation Specification	Description	Désignation	Denominación
8	141	2	2	367 905 952		SCHRAUBE	M5X40	SOCKET HEAD BOLT	VIS	TORNILLO
8	142	1	1	388 301 400		SCHALLDÄMPFER	INC.143	EXHAUST MUFFLER	POT D'ÉCHAPPEMENT	SILENCIADOR
8	143	1	1	381 300 801		FUNKENSCHUTZSIEB		SPARK ARRESTER SCREEN	TAMIS	TAMIZ
8	144	1	1	381 350 430		DICHTUNG		MUFFLER GASKET	JOINT	JUNTA
8	145	1	1	388 701 000		KABEL KPL.	1	WIRE CPL.	CÂBLE COMPLET	CABLE CPL
8	146	1	1	388 701 100		KABEL	2	WIRE	CÂBLE	CABLE
8	147	1	1	367 750 010		STECKERKAPPE		PLUG CAP	CAPUCHON DE FICHE	TAPA DEL ENCHUFE
8	148	1	1	367 324 891		STECKERKAPPENFEDER		PLUG CAP SPRING	RESSORT CAPUCHON DE FICHE	MUELLE TAPA DEL ENCHUFE
8	149	1	1	367 168 501		ZÜNDSPULE		IGNITION COIL	BOBINE D' ALLUMAGE	BOBINA DE ENCENDIDO
8	150	2	2	388 904 997		INNEN-6KT-SCHRAUBE	M4X20	SOCKET HEAD BOLT	VIS	TORNILLO
8	151	1	1	388 006 994		BOLZEN	M6X16(W,SW)	BOLT ASSEMBLY	GOUPILLE	PERNO
8	152	1	1	388 750 020		POLRAD		FLYWHEEL	VOLANT	VOLANTE

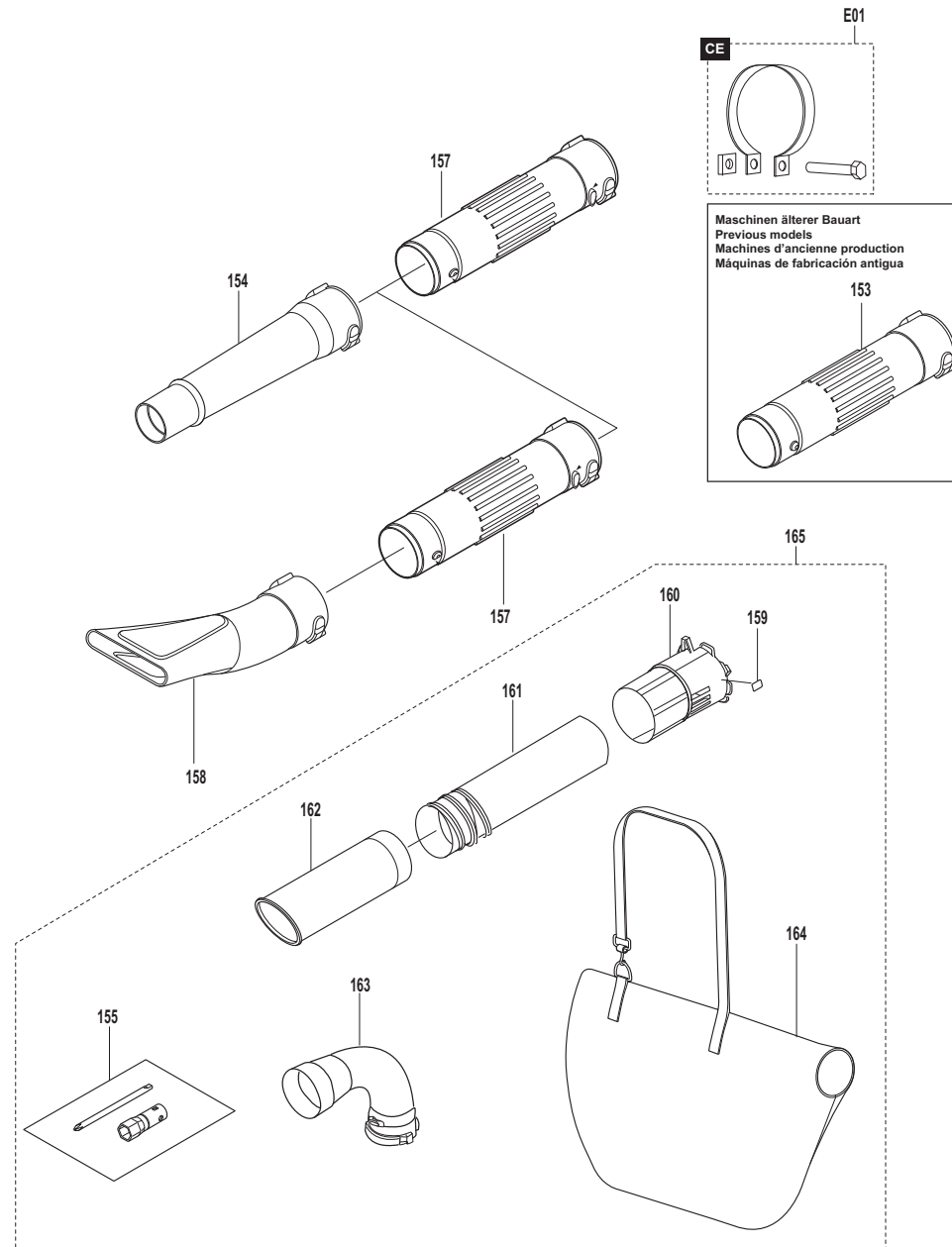

PB-250.4, PB-251.4

9

Zubehör
Accessories
Accessoires
Accesorios**DOLMAR**A member of the **Makita** Group

Seite / Page	Pos.	PB-250.4	PB-251.4 (USA)	Teil-Nr. Part No. No. de pièce No. de pieza	Hinweise Notes Renseign. Nota	Bezeichnung	Spezifikation Specification	Description	Désignation	Denominación
9	153	1	1	381 950 090	=> 2006-08	BLASROHR		PIPE	TUYAU DE SOUFFLAGE	TUBO DE INSUFLAR
9	154	1	1	388 950 100		RUNDDÜSE		END PIPE	BUSE RONDE	BOQUILLA REDONDA
9	155	1	1	388 905 900	ACC.	WERKZEUGSATZ		TOOL	OUTILS CPL.	HERRAMIENTAS CPL.
9	157	1	1	381 950 091	ACC.	BLASROHR		PIPE	TUYAU DE SOUFFLAGE	TUBO DE INSUFLAR
9	158	1	1	388 950 110	ACC.	FLACHDÜSE		END PIPE	BUSE PLATE	BOQUILLA PLANA
9	159	1	1	388 950 480	ACC.	SCHILD		MARK LABEL 4	PLAQUE	CALCOMANIA
9	160	1	1	388 950 360	ACC.	SAUGROHR 1		PIPE 1	TUYAU D'ASPIRATION 1	TUBO DE ASPIRACIÓN 1
9	161	1	1	388 950 370	ACC.	SAUGROHR 2		PIPE 2	TUYAU D'ASPIRATION 2	TUBO DE ASPIRACIÓN 2
9	162	1	1	388 950 380	ACC.	SAUGROHR 3		PIPE 3	TUYAU D'ASPIRATION 3	TUBO DE ASPIRACIÓN 3
9	163	1	1	377 950 280	ACC.	ROHRBOGEN		ELBOW	COUDE DE TUYAU	CODO
9	164	1	1	377 900 600	ACC.	AUFFANGSACK		DUST BAG	SAC DE RECEPTION	SACO DE RECEPCIÓN
9	165	1		377 195 287	ACC.	SAUG-SET	CE PB-250.4, DOLMAR LOGO	VACUUM SET	SET D'ASPIRATION	ASPIRADOR-KIT
9	165		1	377 195 285	ACC.	SAUG-SET	USA PB-251.4, DOLMAR LOGO	VACUUM SET	SET D'ASPIRATION	ASPIRADOR-KIT
9	E01	1		377 950 850		SCHLAUCHSCHELLE	EU	HOSE CLAMP	BRIDE DE TUYAU	GRAPA DE MANGUERA

PB-250.4, PB-251.4

DOLMAR



A member of the **Takita** Group

	Zeichenerklärung	Key to symbols	Légende	Explicación de símbolos
=> 1999999 2000000 => 2003.04 => TI 2003/07 Acc. = { m Corr.	Produktion bis Serien-Nr. Neues Teil ab Serien-Nr. Neues Teil ab Jahr / Monat Siehe Technische Information Jahr / Nr. Zubehör (nicht im Lieferumfang) Keine Serienausführung, jedoch verwendbar Beinhaltet Positions-Nr. Meterware Druckfehlerberichtigung	Production to serial number New part from serial number New part from Year / Month See Technical Information Year / No. Accessories (not included in the delivery inventory) No standard execution, may be used Contains item number Sold by the meter Error correction	Production jusqu'à n° de série Nouvelle pièce à partir du n° de série Nouvelle pièce à partir de année / mois Voir information technique année / n° Accessoires (non compris dans la livraison) Aucune exécut. en série, cependant utilisable contient n° de numéro Au mètre Rectification d'erreurs	Producción hasta N° de serie Pieza nueva a partir de N° de serie Pieza nueva a partir de año / mes Véase inform. técnico año / N° Accesorios (no incluido en la extensión del suministro) No es de serie, pero sirve Contiene pos N° Por metro Fe de erratas
	Änderungen vorbehalten	Specifications subject to change without notice	Changements sans préavis	Mejoras constructivas sin previo aviso