

Ersatzteilliste
Spare Parts List
Liste de pièces détachées
Lista de piezas de repuesto

2005-10

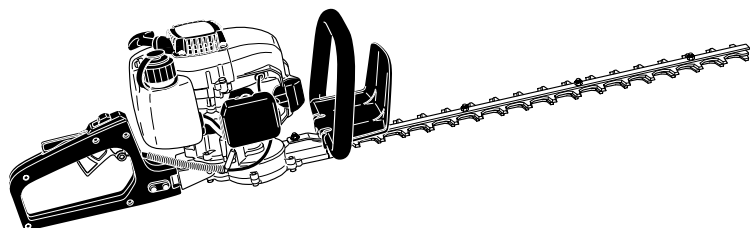

HT-2556 D

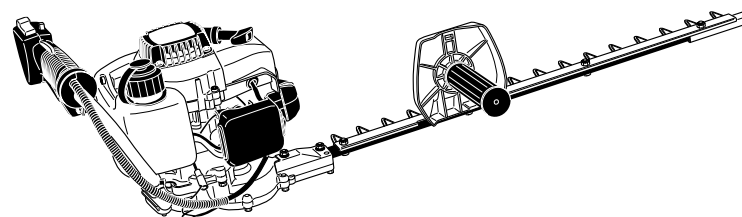

HT-2576 E

DOLMAR



A member of the *Makita* Group

995 700 228 (DE, GB, FR, ES)

HT-2556 D

1

Griff, Getriebe, Scherblatt
Handle, gear, shear blade
Poignée, engrenage, lame
Mango, engranaje, cuchilla de corte

DOLMAR
■■■■■■■■■■

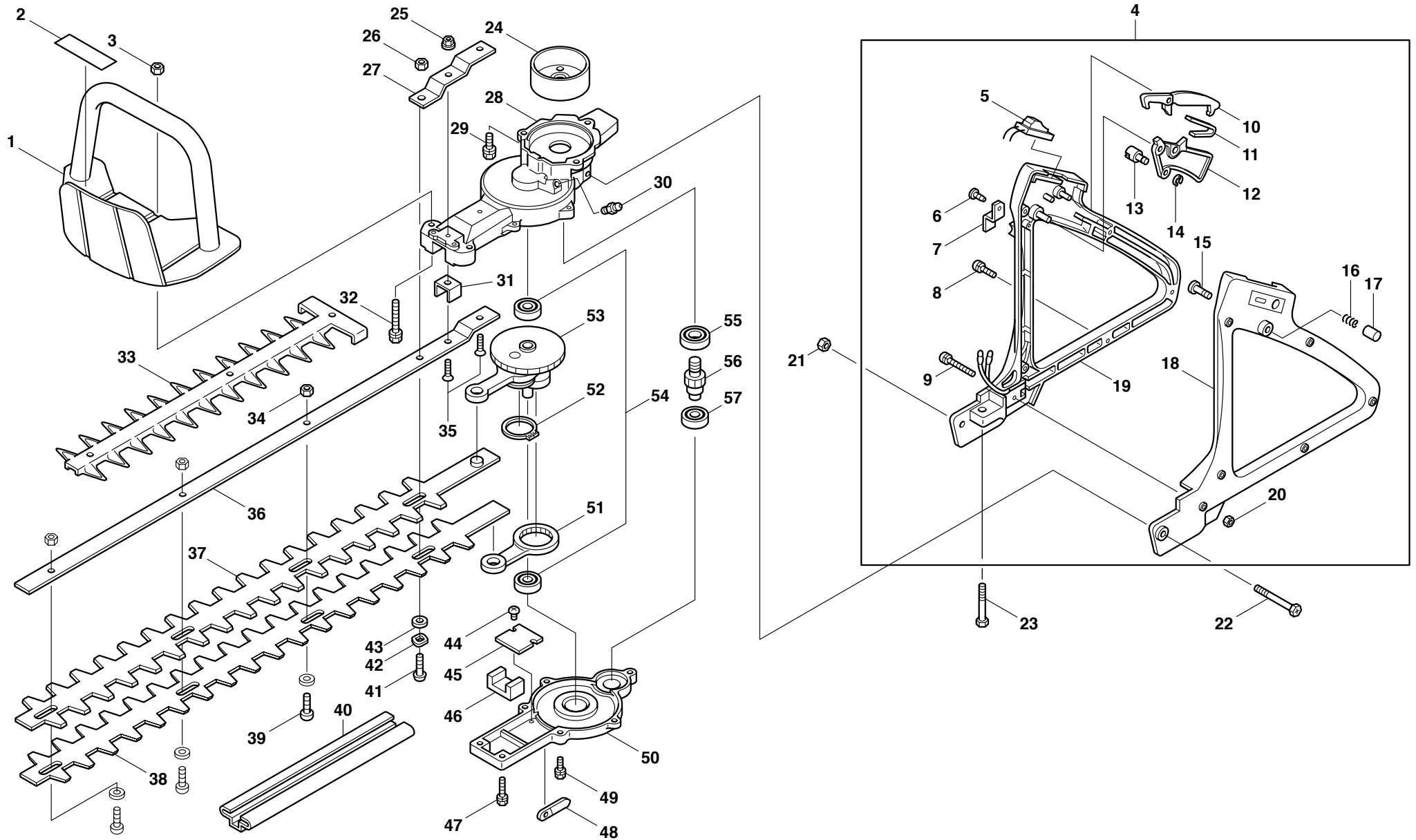

HT-2556 D
HT-2576 E



Seite/Page	Pos.	HT-2556 D	HT-2576 E	Teil-Nr. Part No. No. de pièce No. de pieza	Hinweise Notes Renseign. Nota	Bezeichnung	Spezifikation Specification	Description	Désignation	Denominación
1	1	1		381 155 000		HANDGRIFF VORN		LEVER	POIGNÉE	MANGO
1	2	1		374 635 998		SICHERHEITSAUFKLEBER	F/CE	CAUTION LABEL	PLAQUE	CALCOMANIA
1	3	2		381 106 000		MUTTER	M6	NUT	ECROU	TUERCA
1	4	1		374 118 011		BEDIENUNGSHANDGRIFF KPL.	INC.5-20	REAR HANDLE ASS'Y	LEVIER DE RÉGLAGE, CPL.	BOTÓN DE MANDO, CPL.
1	5	1		381 504 400		SCHALTER KPL.		SWITCH	INTERRUPTEUR CPL.	INTERRUPTOR CPL.
1	6	1		381 040 100		SCHRAUBE	M4X10	SCREW	VIS	TORNILLO
1	7	1		381 121 000		KABELKLEMME		CABLE HOLDER	CRAMP	COLLIER DE SERRAGE
1	8	5		381 704 016		SCHRAUBE	M4X16 (W,SW)	SCREW	VIS	TORNILLO
1	9	1		381 704 030		SCHRAUBE	M4X30 (W,SW)	SCREW	VIS	TORNILLO
1	10	1		381 151 000		RASTHEBEL		STOPPER	LEVIER DE VERROUILLAGE	PALANCA TRINCADA
1	11	1		381 301 000		FEDER		SPRING	RESSORT	MUELLE
1	12	1		381 115 000		GASHEBEL		LEVER	LEVIER DE GAZ	PALANCA DE GAS
1	13	1		381 111 000		AUFNAHME FÜR BOWDENZUG		WIRE END	PORTE-CÂBLE BOWDEN	RECEPCIÓN DEL CABLE BOWDEN
1	14	1		381 000 250		SICHERUNGSRING		SNAP RING	CIRCLIP	ANILLO
1	15	1		381 112 000		STIFT F.GASHEBEL		LEVER PIN	GOUPILLE	PERNO
1	16	1		381 114 000		FEDER		SPRING	RESSORT	MUELLE
1	17	1		381 113 000		KAPPE		PIN CAP	CAPUCHON	CAPUCHON
1	18	1		383 150 000		BEDIENUNGSHANDGRIFF (LINKS)		REAR HANDLE (L)	LEVIER DE RÉGLAGE (GAUCHE)	BOTÓN DE MANDO (IZQUIERDO)
1	19	1		381 149 000		BEDIENUNGSHANDGRIFF (RECHTS)		REAR HANDLE (R)	LEVIER DE RÉGLAGE (DROITE)	BOTÓN DE MANDO (DERECHO)
1	20	6		381 500 400		MUTTER	M4	NUT	ECROU	TUERCA
1	21	1		381 106 000		MUTTER	M6	NUT	ECROU	TUERCA
1	22	1		381 506 050		BOLZEN	M6X50 (W,SW,PW)	BOLT	VIS	TORNILLO
1	23	1		381 506 040		BOLZEN	M6X40	BOLT	VIS	TORNILLO
1	24	1		374 136 141		KUPPLUNGSTROMMEL KPL.		DRUM COMPLETE	TAMBOUR CPL.	TAMBOR CPL.
1	25	1		381 205 000		BUNDMUTTER	M5	FLANGE NUT	ECROU	TUERCA
1	26	1		381 205 000		BUNDMUTTER	M5	FLANGE NUT	ECROU	TUERCA
1	27	1		381 510 200		BEFESTIGUNGLASCHE		PLATE	PLAQUE	PLACA

HT-2556 D
HT-2576 E



Seite/Page	Pos.	HT-2556 D	HT-2576 E	Teil-Nr. Part No. No. de pièce No. de pieza	Hinweise Notes Renseign. Nota	Bezeichnung	Spezifikation Specification	Description	Désignation	Denominación
1	28	1		381 510 000		GETRIEBEGEHÄUSE		UPPER CASE	CARTER D ENGRENAGE	CARTER DE ENGRANAJE
1	29	2		381 406 015		BOLZEN	M6X15	BOLT	VIS	TORNILLO
1	30	1		381 500 010		SCHMIERNIPPEL	M6	GREASE NIPPLE	NIPPLE DE GRAISSAGE	BOQUILLA DE ENGRASE
1	31	1		381 510 300		PLATTE		PLATE	PLAQUE	PLACA
1	32	2		381 406 035		BOLZEN	M6X35	BOLT	VIS	TORNILLO
1	33	1		381 711 000		SCHUTZLEISTE		BLADE GUARD	BARRE DE PROTECTION	BARRA DE PROTECCIÓN
1	34	4		381 406 000		MUTTER	M6	U-NUT	ECROU	TUERCA
1	35	2		381 105 020		SCHRAUBE	M5X20	SCREW	VIS	TORNILLO
1	36	1		374 118 126		FÜHRUNGSLEISTE		BLADE SUPPORT BAR	BARRE DE SERRAGE	BARRE DE MONTAJE
1	37	1		374 077 106		SCHERBLATT OBEN		UPPER BLADE	LAME SUPÉRIEURE	CUCHILLA DE CORTE SUPERIOR
1	38	1		374 077 107		SCHERBLATT UNTEN		LOWER BLADE	LAME	CUCHILLA DE CORTE
1	39	3		381 000 200		SCHRAUBE	L=19	SCREW	VIS	TORNILLO
1	40	1		381 800 203		SCHERBLATTSCHUTZ		BLADE COVER	CARQUOIS DE PROTECTION	CARCAJ DE CONSERVACIÓN
1	41	1		381 000 300		SCHRAUBE	M6X22	SCREW	ECROU	TUERCA
1	42	1		381 906 000		DRUCKSCHEIBE		WAVE WASHER	DISQUE DE PRESSION	DISCO DE PRESSION
1	43	4		374 008 250		SCHEIBE		BLADE SLIDING WASHER	RONDELLE	ARANDELA
1	44	2		381 003 005		SCHRAUBE	M3X5	SCREW	VIS	TORNILLO
1	45	1		374 030 110		FÜHRUNGSBLECH		ROD SLIDING PLATE	TÔLE DE GUIDAGE	CHAPA DE GUÍA
1	46	1		381 510 400		FILZDICHTUNG		FELT	JOINT	JUNTA
1	47	2		381 405 016		BOLZEN	M5X16 (W,SW)	BOLT	VIS	TORNILLO
1	48	1		374 607 997		KLEMMSCHELLE		CLAMP	COLLIER DE SERRAGE	ABRAZADERA DE SUJECIÓN
1	49	5		381 405 016		BOLZEN	M5X16 (W,SW)	BOLT	VIS	TORNILLO
1	50	1		381 510 100		GETRIEBEGEHÄUSE		LOWER CASE	CARTER D ENGRENAGE	CARTER DE ENGRANAJE
1	51	1		374 118 100		PLEUEL		ROD	BIELLE	BIELA
1	52	1		381 302 600		SICHERUNGSRING		SNAP RING	CIRCLIP	ANILLO
1	53	1		374 136 003		ZAHNRAD KPL.		GEAR CRANK ASS'Y	PIGNON COMPLET	PIÑÓN COMPLETO
1	54	2		381 300 608		KUGELLAGER	ZZ 608	BALL BEARING	ROULEMENT A BILLES	RODAMIENTO DE BOLAS

HT-2556 D
HT-2576 E



Seite/Page	Pos.	HT-2556 D	HT-2576 E	Teil-Nr. Part No. No. de pièce No. de pieza	Hinweise Notes Renseign. Nota	Bezeichnung	Spezifikation Specification	Description	Désignation	Denominación
1	55	1		381 406 001		KUGELLAGER	UU 6001	BALL BEARING	ROULEMENT A BILLES	RODAMIENTO DE BOLAS
1	56	1		374 136 142		RITZEL		PINION GEAR	PIGNON	PIÑÓN
1	57	1		381 300 608		KUGELLAGER	ZZ 608	BALL BEARING	ROULEMENT A BILLES	RODAMIENTO DE BOLAS

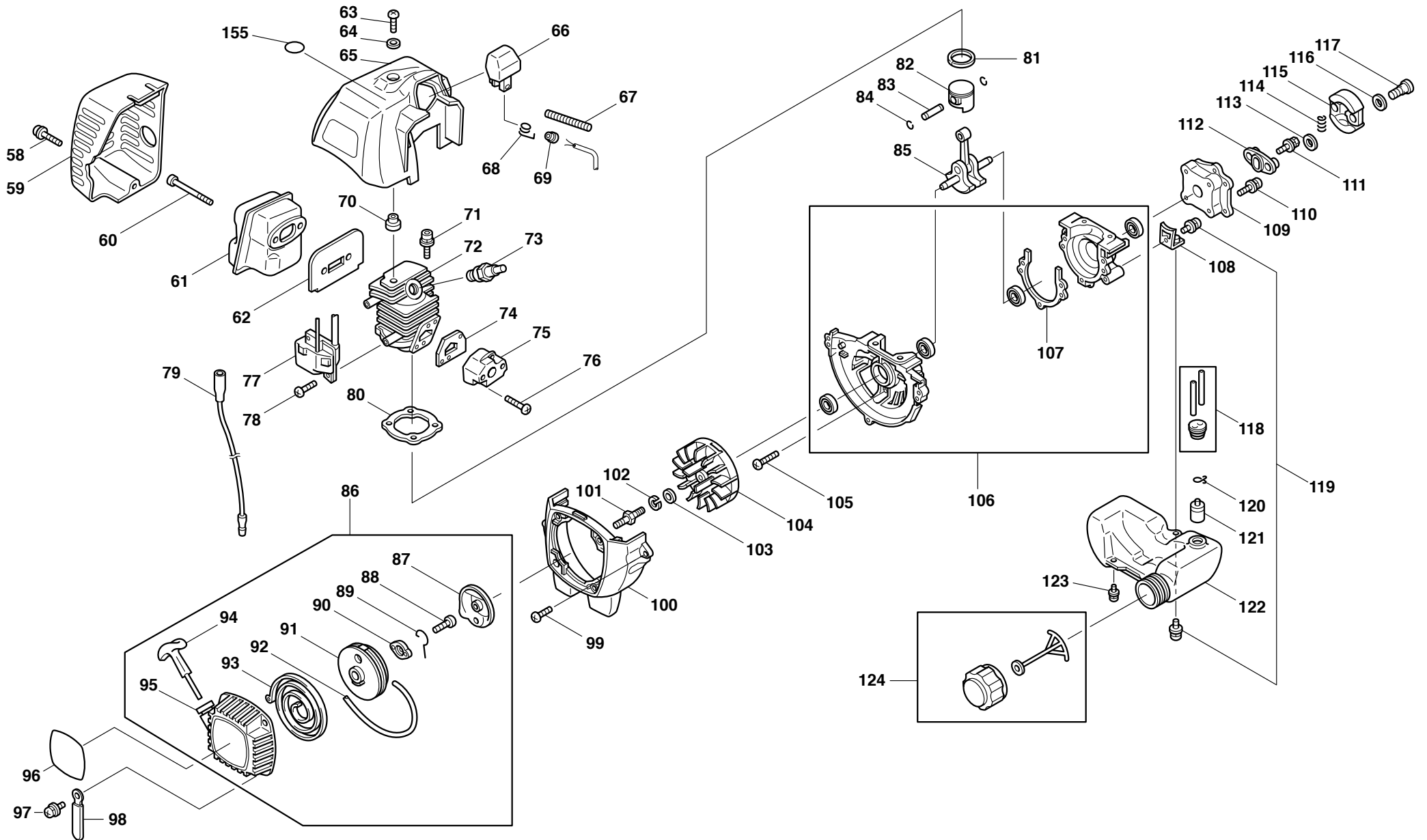

HT-2556 D
HT-2576 E



Seite/Page	Pos.	HT-2556 D	HT-2576 E	Teil-Nr. Part No. No. de pièce No. de pieza	Hinweise Notes Renseign. Nota	Bezeichnung	Spezifikation Specification	Description	Désignation	Denominación
2	58	1		381 005 929		SCHRAUBE KPL.		SCREW ASSY	VIS CPL.	TORNILLO CPL.
2	59	1		374 350 050		SCHALLDÄMPFERHAUBE		MUFFLER COVER	CAPOT POUR POT D'ÉCHAPPEMENT	TAPA DE SILENCIOSO
2	60	2		381 905 955		SCHRAUBE		SOCKET HEAD BOLT	VIS	TORNILLO
2	61	1		374 307 100		SCHALLDÄMPFER		EXHAUST MUFFLER	POT D'ÉCHAPPEMENT	SILENCIADOR
2	62	1		374 350 010		DICHTUNG SCHALLDÄMPFER		MUFFLER GASKET	JOINT DE POT D'ÉCHAPPEMENT	JUNTA DEL SILENCIOSO
2	63	1		374 005 949		SCHRAUBE		SCREW	VIS	TORNILLO
2	64	1		374 007 001		SCHEIBE		WASHER	RONDELLE	ARANDELA
2	65	1		374 550 120		ZYLINDERHAUBE		CYLINDER COVER	CAPOT DE CYLINDRE	TAPA PARA CYLINDRO
2	66	1		388 750 330		ZÜNDKERZENSTECKER		PLUG CAP	COSSE DE BOUGIE	TAPÓN
2	67	1		374 104 995		SCHLAUCH		TUBE	TUBE	TUBO
2	68	1		377 400 993		STECKERKAPPENFEDER		PLUG CAP SPRING	RESSORT CAPUCHON DE FICHE	MUELLE TAPA DEL ENCHUFE
2	69	1		374 750 030		GUMMITÜLLE		GROMMET	GAIN CAOUTCHOUC	BOQUILLA DE GAUCHO
2	70	1		374 350 300		DISTANZSTÜCK		SPACER	PIECE DISTANCE	ANILLO SEPARADOR
2	71	2		382 905 973		SCHRAUBE	M5X20 (W/W&SW)	SOCKET HEAD BOLT	VIS	TORNILLO
2	72	1		368 150 020		ZYLINDER		CYLINDER	CYLINDRE	CYLINDRO
2	73	1		381 014 981		ZÜNDKERZE		SPARK PLUG	BOUGIE	BUIJA
2	74	1		374 350 020		DICHTUNG		INSULATOR GASKET	JOINT	JUNTA
2	75	1		381 301 400		ZWISCHENFLANSCH		INSULATOR COMPL.	BRIDE INTERMÉDIAIRE	BRIDA INTERMEDIA
2	76	2		381 005 950		SCHRAUBE	M5X25	SCREW	VIS	TORNILLO
2	77	1		374 700 102		ZÜNDER		COIL	BOBINE D'ALLUMAGE	BOBINA ENCEND.
2	78	2		367 004 992		SCHRAUBE KPL.	M4X20	SCREW ASS'Y	VIS CPL.	TORNILLO CPL.
2	79	1		374 700 500		KABEL KPL.		WIRE COMPLETE	CÂBLE COMPLET	CABLE CPL.
2	80	1		388 150 230		DICHTUNG		CYLINDER GASKET	JOINT	JUNTA
2	81	1		382 250 070		KOLBENRING		PISTON RING	SEGMENT DE PISTON	SEGMENT DE PISTÓN
2	82	1		388 250 190		KOLBEN		PISTON	PISTON	PISTÓN
2	83	1		388 250 260		KOLBENBOLZEN		PISTON PIN	AXE DE PISTON	AXE DE PISTÓN
2	84	2		388 508 997		SPRENGRING		CLIP	ANNEAU RESSORT	ANILO ELASTICO

HT-2556 D
HT-2576 E



Seite/Page	Pos.	HT-2556 D	HT-2576 E	Teil-Nr. Part No. No. de pièce No. de pieza	Hinweise Notes Renseign. Nota	Bezeichnung	Spezifikation Specification	Description	Désignation	Denominación
2	85	1		374 200 200		KURBELWELLE KPL.		CRANKSHAFT COMPLETE	VILEBREQUIN CPL.	CIGÜEÑAL CPL.
2	86	1		381 505 200		STARTERGEHÄUSE	INC.87-95	REWIND STARTER	CARTER LANCEUR	CAJA DE ARRANQUE
2	87	1		381 550 590		STARTERRAD		PULLEY	ROUE DÉMARREUR	RUEDA DE ARRANQUE
2	88	1		367 500 206		SCHRAUBE KPL.		SET SCREW	VIS CPL.	TORNILLO CPL.
2	89	1		367 500 210		MITNEHMERBÜGEL		SWING ARM	ETRIER D'ENTRAINEMENT	BRAZO OSCILANTE
2	90	1		367 500 211		AUFNAHME F. MITNEHMERBÜGEL		COLLAR	LOGEMENT POU ETRIER	ANILLO DE RETENCIÓN
2	91	1		383 500 203		SEILTROMMEL		REEL	TAMBOUR DE CÂBLE	TAMBOR PARA CUERDA
2	92	1		381 501 602		ANWERFSEIL	Ø 3,5 x 850 mm	STARTER ROPE	CORDE DE LANCEUR	CUERDA DE ARRANQUE
2	92	1		985 000 155		ANWERFSEIL	Ø 3,5 x 100 m	STARTER ROPE	CORDE DE LANCEUR	CUERDA DE ARRANQUE
2	93	1		381 500 205		RÜCKHOLFEDER		SPIRAL SPRING	RESSORT DE RAPPEL	RESORTE RETENCION
2	94	1		388 500 402		ANWERFGRIF		HANDLE	POIGNÉE DE LANCEMENT	TIRADOR DE ARRANQUE
2	95	1		381 500 104		DÄMPFER		DAMPER	AMORTISSEUR	AMORTIGUADOR
2	96	1		381 950 920		SCHILD		MODEL LABEL	PLAQUE	PLACA
2	97	4		381 004 976		SCHRAUBE KPL.		SCREW ASSEMBLY	VIS CPL.	TORNILLO CPL.
2	98	1		374 605 998		KLEMMSCHELLE		CLAMP	COLLIER DE SERRAGE	ABRAZADERA DE SUJECIÓN
2	99	3		381 005 935		SCHRAUBE KPL.	M5X18 (W,SW)	SCREW ASSY	VIS CPL.	TORNILLO CPL.
2	100	1		381 550 600		VENTILATORGEHÄUSE		BLOWER HOUSING	CARTER DE VENTILATEUR	CARCASA DEL VENTILADOR
2	101	1		381 750 140		BOLZEN		BOLT	VIS	TORNILLO
2	102	1		383 200 600		FEDERSCHEIBE		SPRING WASHER	RONDELLE A RESSORT	ARANDELA ELASTICO
2	103	1		381 120 600		SCHEIBE		WASHER	RONDELLE	ARANDELA
2	104	1		381 704 101		POLRAD		FLYWHEEL	VOLANT	VOLANTE
2	105	3		388 005 952		SCHRAUBE	M5X25	SCREW	VIS	TORNILLO
2	106	1		374 100 300		KURBELGEHÄUSE KPL.	INC.107	CRANKCASE COMPLETE	CARTER-VILEBREQUIN CPL.	CARTER CIGÜEÑAL CPL.
2	107	1		388 150 220		DICHTUNG		CRANKCASE GASKET	JOINT	JUNTA
2	108	1		374 600 200		TANKPLATTE KPL.		TANK PLATE COMPLETE	PLAQUE	PLACA
2	109	1		374 118 124		ZWISCHENFLANSCH		SPACER	BRIDE INTERMÉDIAIRE	BRIDA INTERMEDIA
2	110	4		381 005 935		SCHRAUBE KPL.	M5X18 (W,SW)	SCREW ASSY	VIS CPL.	TORNILLO CPL.

HT-2556 D
HT-2576 E



Seite/Page	Pos.	HT-2556 D	HT-2576 E	Teil-Nr. Part No. No. de pièce No. de pieza	Hinweise Notes Renseign. Nota	Bezeichnung	Spezifikation Specification	Description	Désignation	Denominación
2	111	1		383 200 605		BOLZEN KPL.	W/W&SW	BOLT ASS'Y	VIS CPL.	TORNILLO CPL.
2	112	1		374 250 000		HALTER		HOLDER	BRIDE	FIJACION
2	113	2		374 250 060		SCHEIBE		WASHER	RONDELLE	ARANDELA
2	114	1		374 850 050		FEDER		CLUTCH SPRING	RESSORT	MUELLE
2	115	2		374 250 080		FLIEHGEWICHT		CLUTCH SHOE	POIDS DE REGULATION	PESA DE REGULACIÓN
2	116	2		383 008 991		SCHEIBE	M8	WASHER	RONDELLE	ARANDELA
2	117	2		381 250 040		SCHRAUBE		CLUTCH BOLT	VIS	TORNILLO
2	118	1		374 601 200		SCHLAUCH KPL.		TUBE ASS'Y	TUBE CPL.	TUBO CPL.
2	119	2		381 005 929		SCHRAUBE KPL.		SCREW ASSY	VIS CPL.	TORNILLO CPL.
2	120	1		381 105 999		SCHLAUCHKLEMME		HOSE CLAMP	COLLIER	ABRAZADERA
2	121	1		382 650 390		SAUGKOPF		FILTER	TETE D'ASPIRATION	CABEZA DE ASPIRACION
2	122	1		374 602 500		KRAFTSTOFFTANK KPL.		FUEL TANK COMPLETE	RESERVOIR D'ESSENCE CPL.	DEPÓSITO DE COMBUSTIBLE CPL.
2	123	2		381 005 980		SCHNEIDSCHRAUBE	M5X18	TAPPING SCREW	VIS DE COUPE	TORNILLO DE ROSCA CORTANTE
2	124	1		377 605 900		TANKVERSCHLUSS KPL.		FUEL TANK CAP COMPLETE	BOUCHON RÉSERVOIR CPL.	CIERRE DEPÓSITO CPL.

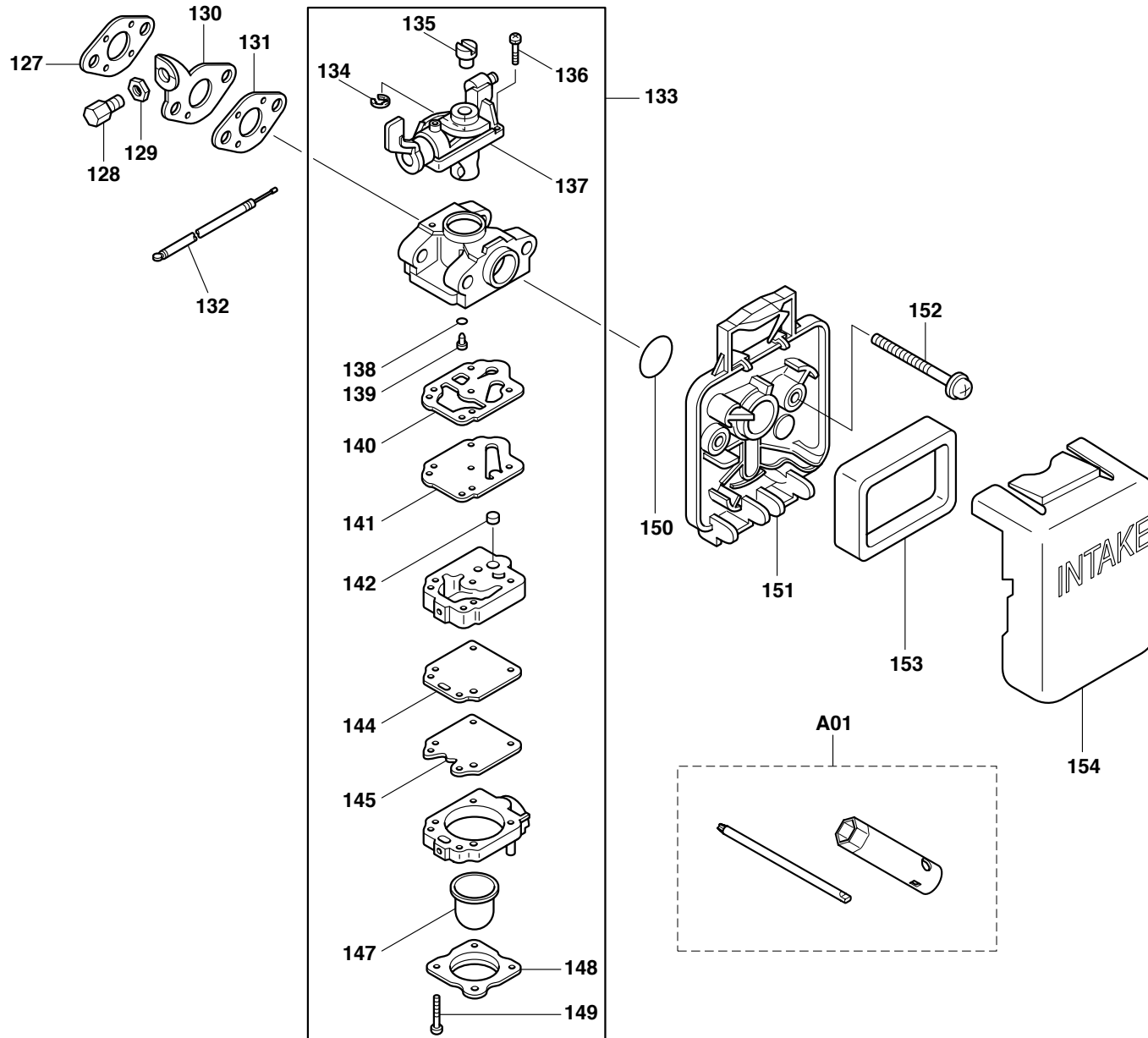

HT-2556 D
HT-2576 E



Seite/Page	Pos.	HT-2556 D	HT-2576 E	Teil-Nr. Part No. No. de pièce No. de pieza	Hinweise Notes Renseign. Nota	Bezeichnung	Spezifikation Specification	Description	Désignation	Denominación
3	127	1		381 350 280		DICHTUNG		SPACER GASKET	JOINT	JUNTA
3	128	1		381 602 002		STELLSCHRAUBE		CABLE ADJUST SCREW	VIS D'AJUSTAGE	PERNO DE AJUSTE
3	129	1		377 270 600		MUTTER	M6	NUT	ECROU	TUERCA
3	130	1		374 650 190		GASZUGHALTER		CABLE BRACKET	SUPPORT DU DISPOS. DE TIRAGE	TRACCIÓN BOWDEN, SOPORTE
3	131	1		381 350 280		DICHTUNG		SPACER GASKET	JOINT	JUNTA
3	132	1		374 002 983		BOWDENZUG		CONTROL CABLE	CÂBLE DE COMMANDE	TRANSMIS. FLEXIBLE BOWDEN
3	133	1		381 608 500		VERGASER KPL.	INC.134-149	CARBURETOR	CARBURATEUR CPL.	CARBURADOR CPL.
3	134	1		381 600 512		SICHERUNGSRING		RING	RONDELLE SECURITE	ARANDELA SEGURIDAD
3	135	1		381 601 804		AUFNAHME FÜR BOWDENZUG		SWIVEL	PORTE-CÂBLE BOWDEN	RECEPCIÓN DEL CABLE BOWDEN
3	136	2		388 600 803		FLACHKOPFSCHRAUBE		PAN HEAD SCREW	VIS À TÊTE CYLINDRIQUE	TORNILLO DE CABEZA PLANA
3	137	1		383 600 201		DROSSEL		THROTTLE VALVE ASS'Y	ÉTRANGLEMENT	REGULADOR DE MOTOR
3	138	1		381 600 101		O-RING		O RING	BAGUE-JOINT	ANILLO DE GUARNICIÓN
3	139	1		374 600 401		DÜSE		JET	GICLEUR	TOBERA
3	140	1		381 600 103		DICHTUNG		PUMP GASKET	JOINT	JUNTA
3	141	1		381 600 104		PUMPENMEMBRANE		PUMP DIAPHRAGM	MEMBRANE DE POMPE	MEMBRANAS DE LA BOMBA
3	142	1		381 600 401		FILTER		INLET SCREEN	FILTRE	FILTRO
3	144	1		381 604 604		DICHTUNG		METERING DIAPHRAGM GASKET	MEMBRANE DE COMM.	MEMBRANAS DE MANDO
3	145	1		381 600 525		STEUERMENBRANE		METERING DIAPHRAGM ASS'Y	MEMBRANE DE COMM.JEU	MEMBRANAS DE MANDO JUEGO
3	147	1		381 600 115		PRIMER		PRIMER PUMP	POMPE DE PEAU	BOMBA DE PIEL
3	148	1		374 604 605		PRIMERDECKEL		PRIMER PUMP COVER	COUVERCLE DE POMPE PRIMER	TAPA DEL PRIMARIO
3	149	4		381 604 601		SCHRAUBE		PUMP COVER SCREW	VIS	TORNILLO
3	150	1		374 606 100		O-RING		O RING	BAGUE-JOINT	ANILLO DE GUARNICIÓN
3	151	1		374 300 302		LUFTFILTERBODEN		AIR CLEANER HOUSING COMPLETE	PLAQUE DE FILTRE A AIR CPL.	GRUPO DE LA PLANCHA DEL FILTRO
3	152	2		374 330 565		SCHRAUBE KPL.		SCREW ASS'Y	VIS CPL.	TORNILLO CPL.
3	153	1		374 300 401		LUFTFILTER		AIR FILTER	FILTRE À AIR	FILTRO DE AIRE
3	154	1		374 302 001		LUFTFILTERDECKEL		AIR CLEANER COVER	COUVERCLE DE FILTRE A AIR	CUBIERTA DEL FILTRO DE AIRE
3	A01	1		377 900 100		WERKZEUGSATZ		TOOL	OUTILS CPL	HERRAMIENTAS CPL.

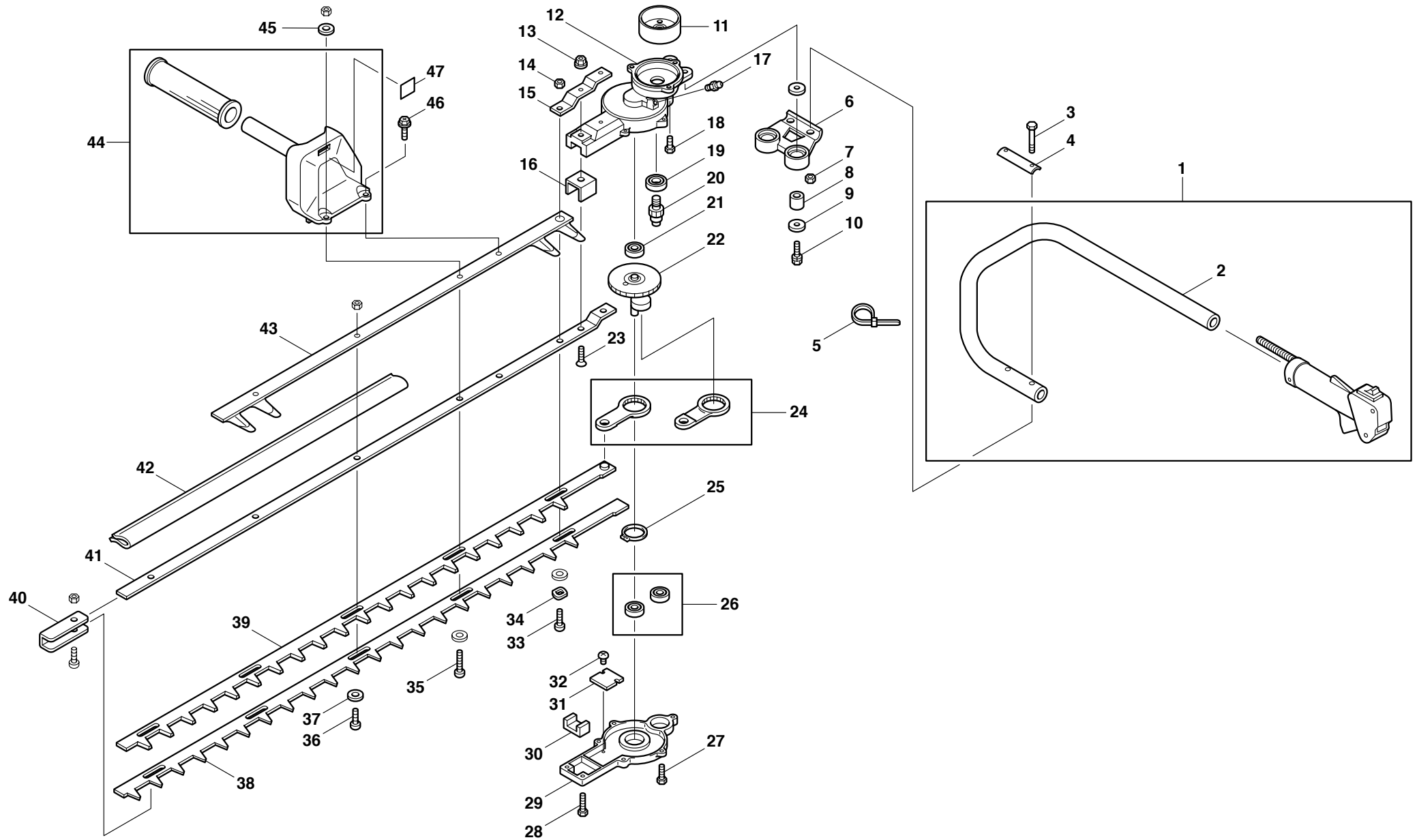

HT-2556 D
HT-2576 E



Seite/Page	Pos.	HT-2556 D	HT-2576 E	Teil-Nr. Part No. No. de pièce No. de pieza	Hinweise Notes Renseign. Nota	Bezeichnung	Spezifikation Specification	Description	Désignation	Denominación
4	1		1	381 004 700		BEDIENUNGSHANDGRIFF KPL.	INC.2	CONTROL LEVER ASSY	LEVIER DE RÉGLAGE, CPL.	BOTÓN DE MANDO, CPL.
4	2		1	374 136 149		GRIFFROHR (LINKS)		HANDLE (LEFT)	TUBE DE POIGNÉE GAUCHE	TUBO DE MANGO IZQUIERDO
4	3		2	381 005 030		BOLZEN	M5X30	BOLT	VIS	TORNILLO
4	4		1	374 136 103		GRIFFPLATTE		HANDLE FITTING	PLAQUE À POIGNÉE	PLACA DE ASIDERO
4	5		1	381 500 210		KABELBINDER		CORD BINDER	BRIDE DE FIXATION	ABRAZADERA
4	6		1	374 136 100		GRIFFHALTERUNG		HANDLE HOLDER	PORTE-POIGNÉE	MONTURA DE EMPUÑADURA
4	7		2	381 005 000		MUTTER	M5	NUT	ECROU	TUERCA
4	8		4	374 136 102		SCHWINGUNGSDÄMPFER		ANTI-VIBRATION RUBBER	AMORTISSEUR	AMORTIGUADOR
4	9		2	374 136 104		ABDECKUNG		FITTING RUBBER	COUVERCLE	CUBIERTA
4	10		2	381 406 035		BOLZEN	M6X35	BOLT	VIS	TORNILLO
4	11		1	374 136 141		KUPPLUNGSTROMMEL KPL.		DRUM COMPLETE	TAMBOUR CPL.	TAMBOR CPL.
4	12		1	381 610 000		GETRIEBEGEHÄUSE		UPPER CASE	CARTER D ENGRENAGE	CARTER DE EBGRANAJE
4	13		2	381 205 000		BUNDMUTTER	M5	FLANGE NUT	ECROU	TUERCA
4	14		5	381 406 000		MUTTER	M6	U-NUT	ECROU	TUERCA
4	15		1	381 510 200		BEFESTIGUNGSLASCHE		PLATE	PLAQUE	PLACA
4	16		1	381 510 300		PLATTE		PLATE	PLAQUE	PLACA
4	17		1	381 500 010		SCHMIERNIPPEL	M6	GREASE NIPPLE	NIPPLE DE GRAISSAGE	BOQUILLA DE ENGRASE
4	18		3	381 406 016		BOLZEN	M6X16	BOLT	VIS	TORNILLO
4	19		1	381 406 001		KUGELLAGER	UU 6001	BALL BEARING	ROULEMENT A BILLES	RODAMIENTO DE BOLAS
4	20		1	374 136 142		RITZEL		PINION GEAR	PIGNON	PIÑÓN
4	21		1	381 300 608		KUGELLAGER	ZZ 608	BALL BEARING	ROULEMENT A BILLES	RODAMIENTO DE BOLAS
4	22		1	374 136 003		ZAHNRAD KPL.		GEAR CRANK ASS'Y	PIGNON COMPLET	PIÑÓN COMPLETO

HT-2556 D
HT-2576 E



Seite/Page	Pos.	HT-2556 D	HT-2576 E	Teil-Nr. Part No. No. de pièce No. de pieza	Hinweise Notes Renseign. Nota	Bezeichnung	Spezifikation Specification	Description	Désignation	Denominación
4	23		2	381 105 020		SCHRAUBE	M5X20	SCREW	VIS	TORNILLO
4	24		2	374 118 100		PLEUEL		ROD	BIELLE	BIELA
4	25		1	381 302 600		SICHERUNGSRING		SNAP RING	CIRCLIP	ANILLO
4	26		2	381 300 608		KUGELLAGER	ZZ 608	BALL BEARING	ROULEMENT A BILLES	RODAMIENTO DE BOLAS
4	27		5	381 405 016		BOLZEN	M5X16 (W,SW)	BOLT	VIS	TORNILLO
4	28		2	381 405 016		BOLZEN	M5X16 (W,SW)	BOLT	VIS	TORNILLO
4	29		1	381 510 100		GETRIEBEGEHÄUSE		LOWER CASE	CARTER D ENGRENAGE	CARTER DE ENGRANAJE
4	30		1	381 510 400		FILZDICHTUNG		FELT	JOINT	JUNTA
4	31		1	374 030 110		FÜHRUNGSBLECH		ROD SLIDING PLATE	TÔLE DE GUIDAGE	CHAPA DE GUÍA
4	32		2	381 003 005		SCHRAUBE	M3X5	SCREW	VIS	TORNILLO
4	33		2	381 000 300		SCHRAUBE	M6X22	SCREW	VIS	TORNILLO
4	34		1	381 906 000		DRUCKSCHEIBE		WAVE WASHER	DISQUE DE PRESSION	DISCO DE PRESSION
4	35		1	381 000 400		SCHRAUBE		SCREW	VIS	TORNILLO
4	36		2	381 000 200		SCHRAUBE	L=19	SCREW	VIS	TORNILLO
4	37		4	374 008 250		SCHEIBE		BLADE SLIDING WASHER	RONDELLE	ARANDELA
4	38		1	374 030 107		SCHERBLATT UNTEN		BLADE (LOWER)	LAME	CUCHILLA DE CORTE
4	39		1	374 030 106		SCHERBLATT OBEN		BLADE (UPPER)	LAME SUPÉRIEURE	CUCHILLA DE CORTE SUPERIOR
4	40		1	374 027 145		VERSTÄRKUNGSBLECH		END REINFORCER	TOLE DE RENFORCEMENT	CHAPA DE REFUERZO
4	41		1	374 136 116		FÜHRUNGSLEISTE		GUIDE PLATE	BARRE DE SERRAGE	BARRE DE MONTAJE
4	42		1	381 810 900		SCHERBLATTSCHUTZ		BLADE COVER	CARQUOIS DE PROTECTION	CARCAJ DE CONSERVACIÓN
4	43		1	381 611 500		SCHUTZLEISTE		PROTECTOR	BARRE DE PROTECTION	BARRA DE PROTECCIÓN
4	44		1	383 400 400		HANDGRIFF RECHTS		RIGHT HANDLE	POIGNÉE DROITE	MANGO DERECHO

HT-2556 D
HT-2576 E



Seite/Page	Pos.	HT-2556 D	HT-2576 E	Teil-Nr. Part No. No. de pièce No. de pieza	Hinweise Notes Renseign. Nota	Bezeichnung	Spezifikation Specification	Description	Désignation	Denominación
4	45		1	381 706 010		SCHEIBE	M6	WASHER	RONDELLE	ARANDELA
4	46		1	381 506 020		BOLZEN	M5X20 (SW,PW)	BOLT	VIS	TORNILLO
4	47		1	374 635 998		SICHERHEITSAUKLEBER	F/CE	CAUTION LABEL	PLAQUE	CALCOMANIA

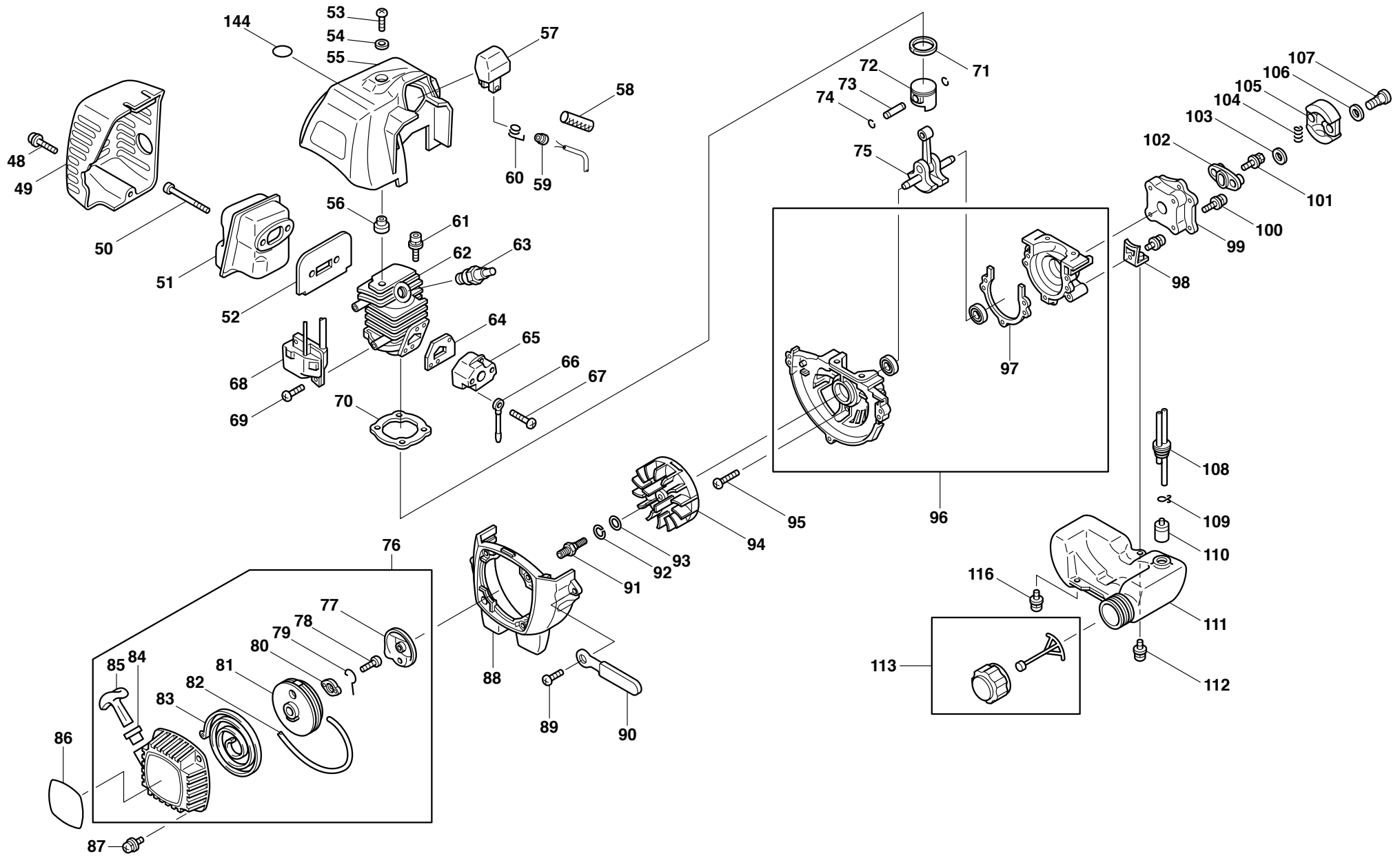

HT-2556 D
HT-2576 E



Seite/Page	Pos.	HT-2556 D	HT-2576 E	Teil-Nr. Part No. No. de pièce No. de pieza	Hinweise Notes Renseign. Nota	Bezeichnung	Spezifikation Specification	Description	Désignation	Denominación
5	48		1	381 005 929		SCHRAUBE KPL.		SCREW ASSY	VIS CPL.	TORNILLO CPL.
5	49		1	374 350 050		SCHALLDÄMPFERHAUBE		MUFFLER COVER	CAPOT POUR POT D'ÉCHAPPEMENT	TAPA DE SILENCIOSO
5	50		2	381 905 955		SCHRAUBE		SOCKET HEAD BOLT	VIS	TORNILLO
5	51		1	374 307 100		SCHALLDÄMPFER		EXHAUST MUFFLER	POT D'ÉCHAPPEMENT	SILENCIADOR
5	52		1	374 350 010		DICHTUNG SCHALLDÄMPFER		MUFFLER GASKET	JOINT DE POT D'ÉCHAPPEMENT	JUNTA DEL SILENCIOSO
5	53		1	374 005 949		SCHRAUBE		SCREW	VIS	TORNILLO
5	54		1	374 007 001		SCHEIBE		WASHER	RONDELLE	ARANDELA
5	55		1	374 550 120		ZYLINDERHAUBE		CYLINDER COVER	CAPOT DE CYLINDRE	TAPA PARA CYLINDRO
5	56		1	374 350 300		DISTANZSTÜCK		SPACER	PIECE DISTANCE	ANILLO SEPARADOR
5	57		1	388 750 330		ZÜNDKERZENSTECKER		PLUG CAP	COSSE DE BOUGIE	TAPÓN
5	58		1	374 104 995		SCHLAUCH		TUBE	TUBE	TUBO
5	59		1	374 750 030		GUMMITÜLLE		GROMMET	GAIN CAOUTCHOUC	BOQUILLA DE GAUCHO
5	60		1	377 400 993		STECKERKAPPENFEDER		PLUG CAP SPRING	RESSORT CAPUCHON DE FICHE	MUELLE TAPA DEL ENCHUFE
5	61		2	382 905 973		SCHRAUBE	M5X20 (W/W&SW)	SOCKET HEAD BOLT M5X20	VIS	TORNILLO
5	62		1	368 150 020		ZYLINDER		CYLINDER	CYLINDRE	CYLINDRO
5	63		1	381 014 981		ZÜNDKERZE		SPARK PLUG	BOUGIE	BUIJA
5	64		1	374 350 020		DICHTUNG		INSULATOR GASKET	JOINT	JUNTA
5	65		1	381 301 400		ZWISCHENFLANSCH		INSULATOR COMPL.	BRIDE INTERMÉDIAIRE	BRIDA INTERMEDIA
5	66		1	381 550 020		KABEL		WIRE	CÂBLE	CABLE
5	67		2	381 005 950		SCHRAUBE	M5X25	SCREW	VIS	TORNILLO
5	68		1	374 700 102		ZÜNDER		COIL	BOBINE D'ALLUMAGE	BOBINA ENCEND.
5	69		2	367 004 992		SCHRAUBE KPL.	M4X20	SCREW ASS'Y	VIS CPL.	TORNILLO CPL.
5	70		1	388 150 230		DICHTUNG		CYLINDER GASKET	JOINT	JUNTA
5	71		1	382 250 070		KOLBENRING		PISTON RING	SEGMENT DE PISTON	SEGMENT DE PISTÓN
5	72		1	388 250 190		KOLBEN		PISTON	PISTON	PISTÓN
5	73		1	388 250 260		KOLBENBOLZEN		PISTON PIN	AXE DE PISTON	AXE DE PISTÓN
5	74		2	388 508 997		SPRENGRING		CLIP	ANNEAU RESSORT	ANILO ELASTICO

HT-2556 D
HT-2576 E



Seite/Page	Pos.	HT-2556 D	HT-2576 E	Teil-Nr. Part No. No. de pièce No. de pieza	Hinweise Notes Renseign. Nota	Bezeichnung	Spezifikation Specification	Description	Désignation	Denominación
5	75		1	374 200 200		KURBELWELLE KPL.		CRANKSHAFT COMPLETE	VILEBREQUIN CPL.	CIGÜEÑAL CPL.
5	76		1	381 505 200		STARTERGEHÄUSE	INC.77-85	REWIND STARTER	CARTER LANCEUR	CAJA DE ARRANQUE
5	77		1	381 550 590		STARTERRAD		PULLEY	ROUE DÉMARREUR	RUEDA DE ARRANQUE
5	78		1	367 500 206		SCHRAUBE KPL.		SET SCREW	VIS CPL.	TORNILLO CPL.
5	79		1	367 500 210		MITNEHMERBÜGEL		SWING ARM	ETRIER D'ENTRAINEMENT	BRAZO OSCILANTE
5	80		1	367 500 211		AUFNAHME F. MITNEHMERBÜGEL		COLLAR	LOGEMENT POU ETRIER	ANILLO DE RETENCIÓN
5	81		1	383 500 203		SEILTROMMEL		REEL	TAMBOUR DE CÂBLE	TAMBOR PARA CUERDA
5	82		1	381 501 602		ANWERFSEIL	Ø 3,5 x 850 mm	STARTER ROPE	CORDE DE LANCEUR	CUERDA DE ARRANQUE
5	82		1	985 000 155		ANWERFSEIL	Ø 3,5 x 100 m	STARTER ROPE	CORDE DE LANCEUR	CUERDA DE ARRANQUE
5	83		1	381 500 205		RÜCKHOLFEDER		SPIRAL SPRING	RESSORT DE RAPPEL	RESORTE RETENCION
5	84		1	381 500 104		DÄMPFER		DAMPER	AMORTISSEUR	AMORTIGUADOR
5	85		1	388 500 402		ANWERFGRIFF		HANDLE	POIGNÉE DE LANCEMENT	TIRADOR DE ARRANQUE
5	86		1	381 950 930		SCHILD		MODEL LABEL	PLAQUE	PLACA
5	87		4	381 004 976		SCHRAUBE KPL.		SCREW ASSEMBLY	VIS CPL.	TORNILLO CPL.
5	88		1	381 550 600		VENTILATORGEHÄUSE		BLOWER HOUSING	CARTER DE VENTILATEUR	CARCASA DEL VENTILADOR
5	89		3	381 005 935		SCHRAUBE KPL.	M5X18 (W,SW)	SCREW ASSY	VIS CPL.	TORNILLO CPL.
5	90		1	374 605 998		KLEMMSCHELLE		CLAMP	COLLIER DE SERRAGE	ABRAZADERA DE SUJECIÓN
5	91		1	381 750 140		BOLZEN		BOLT	VIS	TORNILLO
5	92		1	383 200 600		FEDERSCHEIBE		SPRING WASHER	RONDELLE A RESSORT	ARANDELA ELASTICO
5	93		1	381 120 600		SCHEIBE		WASHER	RONDELLE	ARANDELA
5	94		1	381 704 101		POLRAD		FLYWHEEL	VOLANT	VOLANTE
5	95		3	374 005 952		SCHRAUBE	M5X25	SCREW	VIS	TORNILLO
5	96		1	374 100 300		KURBELGEHÄUSE KPL.	INC.97	CRANKCASE COMPLETE	CARTER-VILEBREQUIN CPL.	CARTER CIGÜEÑAL CPL.
5	97		1	388 150 220		DICHTUNG		CRANKCASE GASKET	JOINT	JUNTA
5	98		1	374 600 200		TANKPLATTE KPL.		TANK PLATE COMPLETE	PLAQUE	PLACA
5	99		1	374 118 124		ZWISCHENFLANSCH		SPACER	BRIDE INTERMÉDIAIRE	BRIDA INTERMEDIA
5	100		4	381 005 935		SCHRAUBE KPL.	M5X18 (W,SW)	SCREW ASSY	VIS CPL.	TORNILLO CPL.

HT-2556 D
HT-2576 E



Seite/Page	Pos.	HT-2556 D	HT-2576 E	Teil-Nr. Part No. No. de pièce No. de pieza	Hinweise Notes Renseign. Nota	Bezeichnung	Spezifikation Specification	Description	Désignation	Denominación
5	101		1	383 200 605		BOLZEN KPL.	W/W&SW	BOLT ASS'Y	VIS CPL.	TORNILLO CPL.
5	102		1	374 250 000		HALTER		HOLDER	BRIDE	FIJACION
5	103		2	374 250 060		SCHEIBE		WASHER	RONDELLE	ARANDELA
5	104		1	374 850 050		FEDER		CLUTCH SPRING	RESSORT	MUELLE
5	105		2	374 250 080		FLIEHGEWICHT		CLUTCH SHOE	POIDS DE REGULATION	PESA DE REGULACIÓN
5	106		2	383 008 991		SCHEIBE	M8	WASHER	RONDELLE	ARANDELA
5	107		2	381 250 040		SCHRAUBE		CLUTCH BOLT	VIS	TORNILLO
5	108		1	374 601 200		SCHLAUCH KPL.		TUBE ASS'Y	TUBE CPL.	TUBO CPL.
5	109		1	381 105 999		SCHLAUCHKLEMME		HOSE CLAMP	COLLIER	ABRAZADERA
5	110		1	382 650 390		SAUGKOPF		FILTER	TETE D'ASPIRATION	CABEZA DE ASPIRACION
5	111		1	374 602 500		KRAFTSTOFFTANK KPL.		FUEL TANK COMPLETE	RESERVOIR D'ESSENCE CPL.	DEPÓSITO DE COMBUSTIBLE CPL.
5	112		2	381 005 929		SCHRAUBE KPL.		SCREW ASSY	VIS CPL.	TORNILLO CPL.
5	113		1	377 605 900		KRAFTSTOFFTANK KPL.		FUEL TANK CAP COMPLETE	RESERVOIR D'ESSENCE CPL.	DEPÓSITO DE COMBUSTIBLE CPL.
5	116		2	381 005 980		SCHNEIDSCHRAUBE	M5X18	TAPPING SCREW	VIS DE COUPE	TORNILLO DE ROSCA CORTANTE

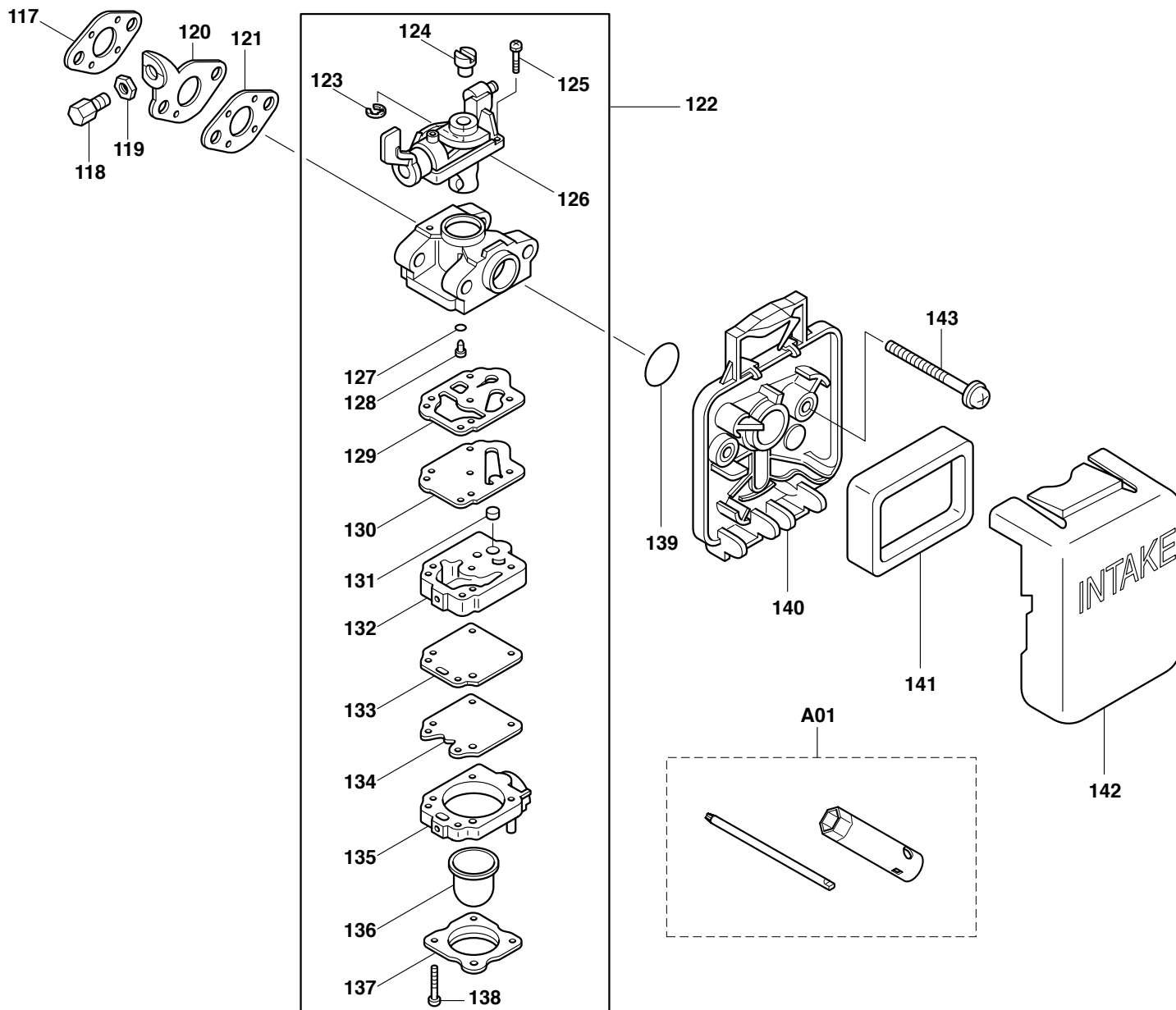

HT-2556 D
HT-2576 E



Seite/Page	Pos.	HT-2556 D	HT-2576 E	Teil-Nr. Part No. No. de pièce No. de pieza	Hinweise Notes Renseign. Nota	Bezeichnung	Spezifikation Specification	Description	Désignation	Denominación
6	117		1	381 350 280		DICHTUNG		SPACER GASKET	JOINT	JUNTA
6	118		1	381 602 002		STELLSCHRAUBE		CABLE ADJUST SCREW	VIS D'AJUSTAGE	PERNO DE AJUSTE
6	119		1	377 270 600		MUTTER	M6	NUT	ECROU	TUERCA
6	120		1	374 650 190		GASZUGHALTER		CABLE BRACKET	SUPPORT DU DISPOS. DE TIRAGE	TRACCIÓN BOWDEN, SOPORTE
6	121		1	381 350 280		DICHTUNG		SPACER GASKET	JOINT	JUNTA
6	122		1	381 608 500		VERGASER KPL.	INC.123-138	CARBURETOR	CARBURATEUR CPL.	CARBURADOR CPL.
6	123		1	381 600 512		SICHERUNGSRING		RING	RONDELLE SECURITE	ARANDELA SEGURIDAD
6	124		1	381 601 804		AUFNAHME FÜR BOWDENZUG		SWIVEL	PORTE-CÂBLE BOWDEN	RECEPCIÓN DEL CABLE BOWDEN
6	125		2	388 600 803		FLACHKOPFSCHRAUBE		PAN HEAD SCREW	VIS À TÊTE CYLINDRIQUE	TORNILLO DE CABEZA PLANA
6	126		1	383 600 201		DROSSEL		THROTTLE VALVE ASS'Y	ÉTRANGLEMENT	REGULADOR DE MOTOR
6	127		1	381 600 101		O-RING		O RING	BAGUE-JOINT	ANILLO DE GUARNICIÓN
6	128		1	374 600 401		DÜSE		JET	GICLEUR	TOBERA
6	129		1	381 600 103		DICHTUNG		PUMP GASKET	JOINT	JUNTA
6	130		1	381 600 104		PUMPENMEMBRANE		PUMP DIAPHRAGM	MEMBRANE DE POMPE	MEMBRANAS DE LA BOMBA
6	131		1	381 600 401		FILTER		INLET SCREEN	FILTRE	FILTRO
6	133		1	381 604 604		DICHTUNG		METERING DIAPHRAGM GASKET	MEMBRANE DE COMM.	MEMBRANAS DE MANDO
6	134		1	381 600 525		STEUERMENBRANE		METERING DIAPHRAGM ASS'Y	MEMBRANE DE COMM.JEU	MEMBRANAS DE MANDO JUEGO
6	136		1	381 600 115		PRIMER		PRIMER PUMP	POMPE DE PEAU	BOMBA DE PIEL
6	137		1	374 604 605		PRIMERDECKEL		PRIMER PUMP COVER	COUVERCLE DE POMPE PRIMER	TAPA DEL PRIMARIO
6	138		4	381 604 601		SCHRAUBE		PUMP COVER SCREW	VIS	TORNILLO
6	139		1	374 606 100		O-RING		O RING	BAGUE-JOINT	ANILLO DE GUARNICIÓN
6	140		1	374 300 302		LUFTFILTERBODEN		AIR CLEANER HOUSING COMPLETE	PLAQUE DE FILTRE A AIR CPL.	GRUPO DE LA PLANCHA DEL FILTRO
6	141		1	374 300 401		LUFTFILTER		AIR FILTER	FILTRE À AIR	FILTRO DE AIRE
6	142		1	374 302 001		LUFTFILTERDECKEL		AIR CLEANER COVER	COUVERCLE DE FILTRE A AIR	CUBIERTA DEL FILTRO DE AIRE
6	143		2	374 330 565		SCHRAUBE KPL.		SCREW ASS'Y	VIS CPL.	TORNILLO CPL.
6	A01		1	377 900 100		WERKZEUGSATZ		TOOL	OUTILS CPL	HERRAMIENTAS CPL.

HT-2556 D
HT-2576 E

Inhaltsverzeichnis
Index
Table des matières
Indice



HT-2556 D	1	Griff, Getriebe, Scherblatt	Handle, gear, shear blade	Poignée, engrenage, lame	Mango, engranaje, cuchilla de corte
	2	Motor	Motor	Moteur	Motor
	3	Vergaser, Luftfilter	Carburetor, air filter	Carbureteur, filter à air	Carburador, filtro de aire
HT-2576 E	4	Griff, Getriebe, Scherblatt	Handle, gear, shear blade	Poignée, engrenage, lame	Mango, engranaje, cuchilla de corte
	5	Motor	Motor	Moteur	Motor
	6	Vergaser, Luftfilter	Carburetor, air filter	Carbureteur, filter à air	Carburador, filtro de aire

	Zeichenerklärung	Key to symbols	Légende	Explicación de símbolos
<p>⇒ 1999999 2000000 ⇒ 2003.04 ⇒ TI 2003/07 Acc. = { m Corr.</p>	<p>Produktion bis Serien-Nr. Neues Teil ab Serien-Nr. Neues Teil ab Jahr / Monat Siehe Technische Information Jahr / Nr. Zubehör (nicht im Lieferumfang) Keine Serienausführung, jedoch verwendbar Beinhaltet Positions-Nr. Meterware Druckfehlerberichtigung</p>	<p>Production to serial number New part from serial number New part from Year / Month See Technical Information Year / No. Accessories (not included in the delivery inventory) No standard execution, may be used Contains item number Sold by the meter Error correction</p>	<p>Production jusqu'à n° de série Nouveau pièce à partir du n° de série Nouveau pièce à partir de année / mois Voir information technique année / n° Accessoires (non compris dans la livraison) Aucune exécut. en série, cependant utilisable contient n° de numéro Au mètre Rectification d'erreurs</p>	<p>Producción hasta N° de serie Pieza nueva a partir de N° de serie Pieza nueva a partir de año / mes Véase inform. técnico año / N° Accesorios (no incluido en la extensión del suministro) No es de serie, pero sirve Contiene pos N° Por metro Fe de erratas</p>
	Änderungen vorbehalten	Specifications subject to change without notice	Changements sans préavis	Mejoras constructivas sin previo aviso